

Appendices / User guides for 1 to 27 Crane Court

1. Fibre Integrated Reception System information
2. Ofnl networks Information
3. Sky Q info
4. Door Entry System
5. Danfoss Heating Programmer Guide
6. Ideal Logic combi boiler guide
7. CO Alarm User Guide
8. Aico Smoke / Heat Detector User Guide
9. Extract ventilation user guide
10. Thermostatic tap user guide
11. Gas Hob user guide
12. Oven user manual

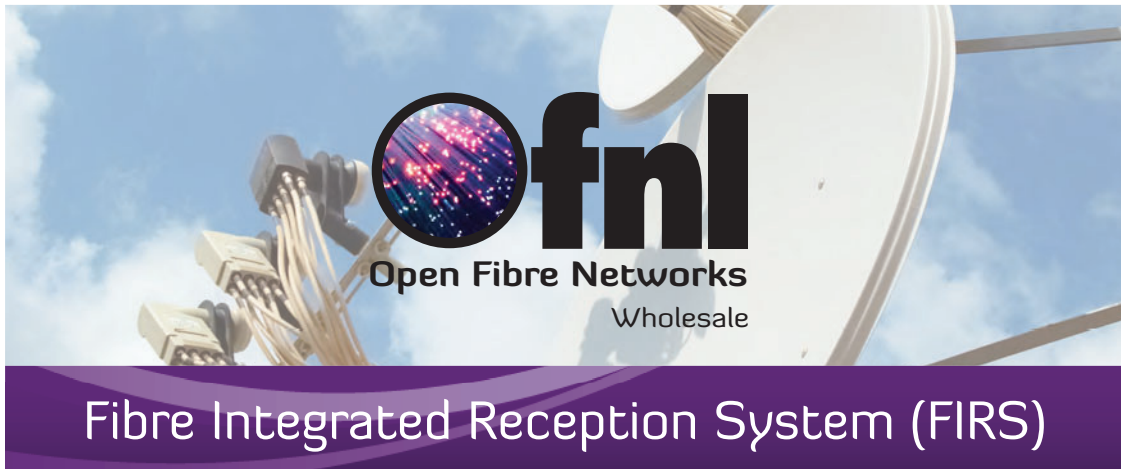

What is FIRS?

FIRS delivers entertainment services, including satellite and terrestrial TV and Digital Audio Broadcast Radio (DAB) to many homes, across the Fibre-to-the-Home network.

FIRS uses satellite dishes and aerials, mounted in a central on-development location. This negates the need for TV aerials or satellite dishes mounted onto new homes!

Freeview, Freesat and Sky are all available, so customers can swap from terrestrial to satellite TV whenever they wish.

OFNL installs FIRS onto developments, utilising their Fibre-to-the-Home network

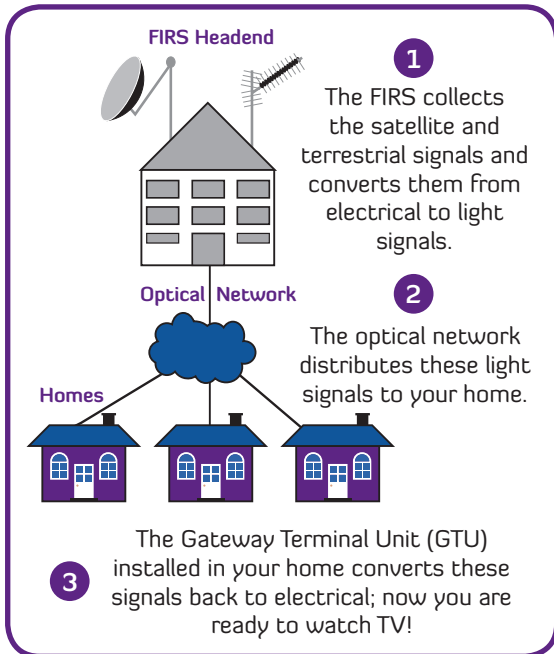

Benefits of FIRS

- ✓ No need for the installation of traditional terrestrial aerials for Freeview or DAB digital radio
- ✓ No unsightly aerials/dishes on the home
- ✓ No need for the installation of a satellite dish when using Freesat or subscribing to Sky services
- ✓ Lower cost than professional installation of conventional aerials
- ✓ Can carry all broadcast TV services to the home, including HD and 3D TV
- ✓ Easy to use and compatible with all standard digital televisions and Set Top Boxes
- ✓ Easy Sky or Freesat installation

GTU and how FIRS works

The Gateway Terminal Unit (GTU) which is situated within the home, will be connected via the installed cabling to media plates (aerial sockets) to enable the customer to connect satellite (Sky or Freesat) or terrestrial (Freeview) set top boxes, or directly into a digital ready TV or DAB radio.

The IRS is installed using the same fibre network that the Telecom services utilise. The developer will define where the customer can locate TVs and Radios within the home. However, it is possible to install additional aerial outlets in a similar manner as a traditional aerial installation.

A typical GTU

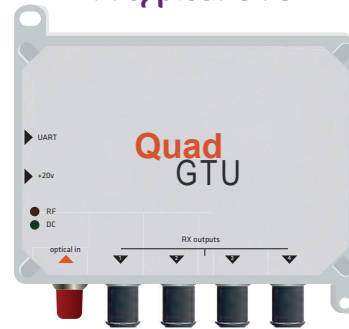

GTU model and colour may vary

The GTU will typically be discretely located in a cupboard or under the stairs (defined by the developer) as there is no requirement to access it every day.

Frequently asked questions

What is FIRS?

FIRS is a facility that distributes satellite, terrestrial TV and radio signals from centralised aerials and dishes to all of the houses across the development. It is distributed through Fibre Optic cables which have already been installed; giving you excellent signal quality and reliable service.

What type of equipment can connect to the FIRS?

Freeview

Connect to the TV or Digibox aerial socket

Freesat

Connect to satellite receiver dish inputs 1 and 2

Sky (+, HD, 3D)

Connect to satellite receiver dish inputs 1 and 2

DAB Radio

Connect to DAB radio aerial Socket

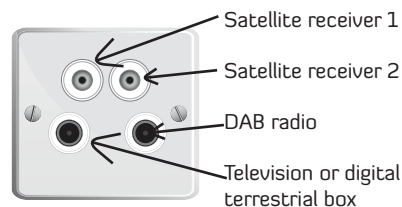

What should I do if I have a fault?

In the first instance, you should check the GTU is powered on and there is not a fault with your equipment, e.g. your TV, Freesat or Sky Set top box.

If you have multiple TV points in your property and only one of these points is not working then there could be a fault with your internal wiring.

Before reporting faults to OFNL please check your internal wiring or use a local TV repair company for assistance. Once you have eliminated this possibility, and you are sure the fault is not with your equipment or internal wiring, please contact **OFNL Customer Services on 02921 678 550**.

Voice, Ultrafast broadband and TV networks

Choice of Service Providers on the OFNL Network for Residential Customers.

Introduction

OFNL are passionate about providing quality, value and choice to residents who live in homes connected to its high-speed Fibre-to-the-Home network.

OFNL provides an 'Open Access' network designed to make it easy for service providers to connect and offer choice to residents, however before they can offer service there is a requirement for them to connect to the OFNL fibre network, either locally at the housing development or at OFNL's national hand-off location.

Choice of Service Providers:

OFNL is in discussions with a number of UK telecom brands and actively encourages service providers to connect to the fibre network. OFNL are excited

by this interest and the benefits it will bring to residents and details will be published when new service providers become available.

OFNL enables service providers to meet government targets of offering all residents on the Open Fibre Network Super-Fast broadband. Superfast is defined as greater than 24Mbps. OFNL delivers ultrafast speeds of up to 1Gbps.

There are currently 16 service providers who can deliver residential services.

Service Providers on the OFNL Network:

Listed below are the details of the residential service providers available across the OFNL network.

Available residential service providers



How to Get Sky Q with OFNL The Next Generation Box

The Sky Q experience

- ✓ Pause, rewind or restart live TV
- ✓ Use Series Link to record a whole series
- ✓ Watch your favourite shows around the home
- ✓ Over 500 hours of recording space to save your favourite shows



Getting Sky Q

If you live on a site where a communal satellite dish has been fitted, a Gateway Terminal Unit (GTU) will have been installed in your home. This enables you to get Sky or terrestrial Freeview services via a set top box.

What you need to do if you want to get Sky Q

If you have a Quad GTU

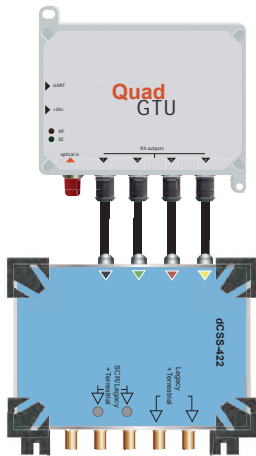

If you have a Quad GTU, the engineer will need to connect a DCSS switch to it, to allow you to receive Sky Q services.

If you have a dSCR GTU



You will not need a DCSS switch to receive Sky Q services - the engineer will connect your GTU to your Sky Q set top box.

When you sign up for services with Sky, please remind Sky that you are on a communal site.

Sky Q Multi room setup

Sky Q provides the ability to watch TV in different rooms via multiple set top boxes. Only the main box needs to be connected to either the dCSS switch or the dSCR GTU.

Watching Freeview

Connect a standard Digital TV to your GTU and watch free to air content.

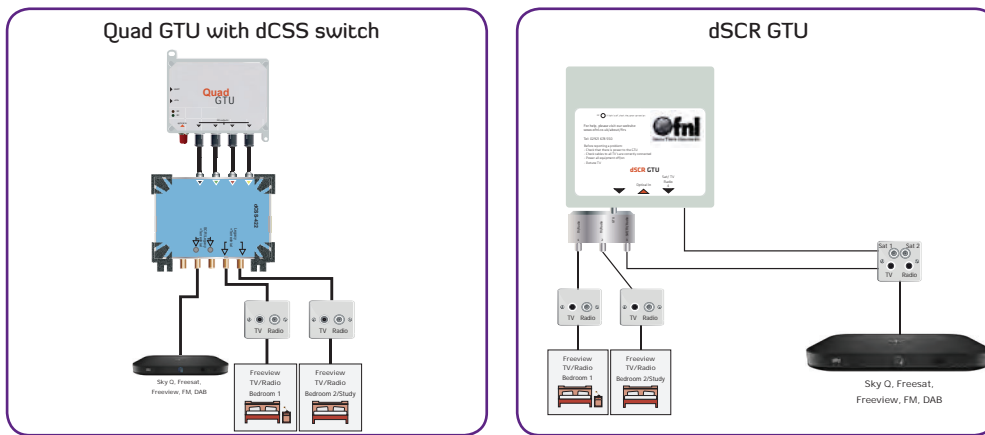

To watch Digital TV on more than two TV's, you may require a distribution amplifier. *OFNL don't supply these. Contact your local aerial/TV supplier to purchase one.*

Plug the 'Distribution Amplifier' into the spare port of the 'dCSS switch' or dSCR. Use additional cables and plug these into the faceplate in each room.

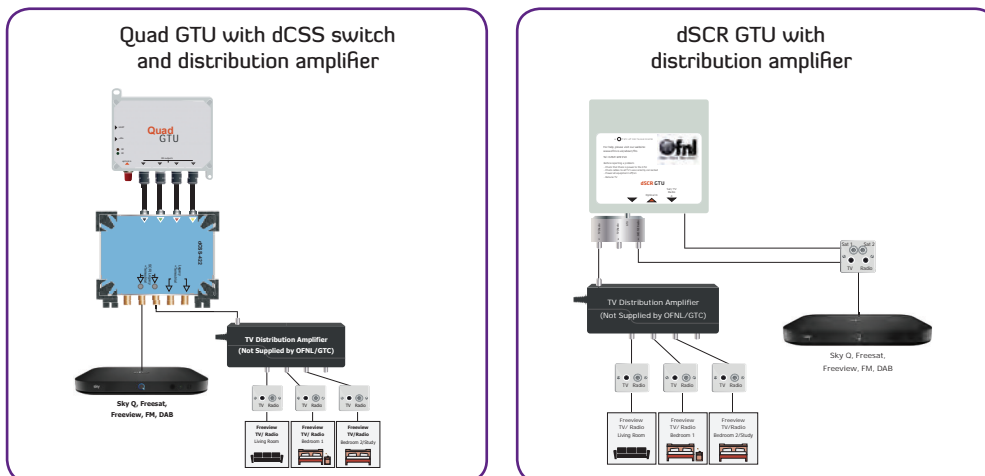



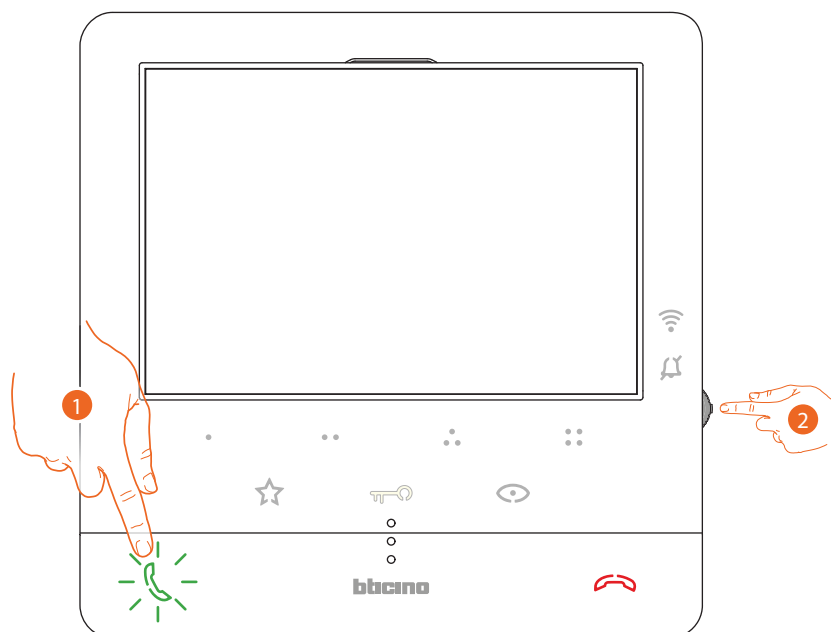

Quick guide

Answer a call

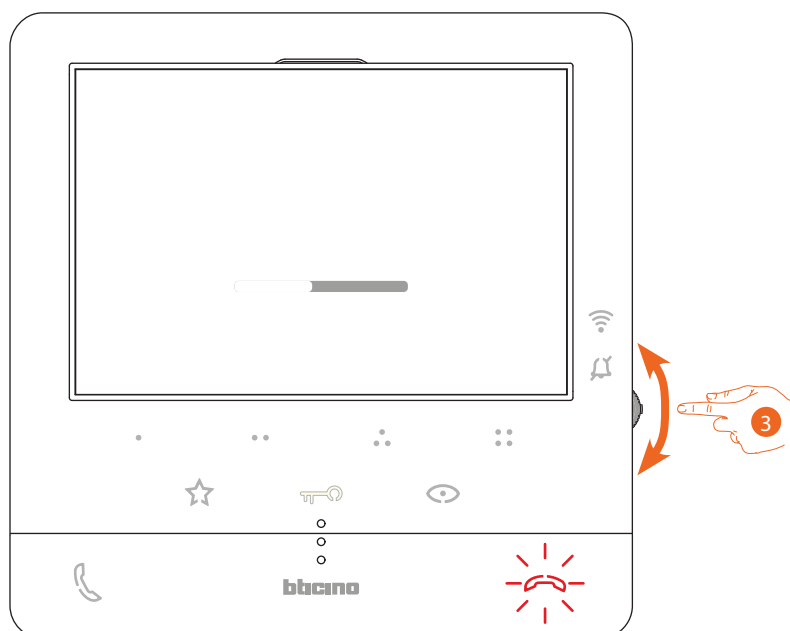

1. Touch to answer the call.
2. If necessary, during the call press the joystick to display the audio/video parameter adjustment icons.



3. Move the joystick up/down to select the type of parameter for which you want to modify the value (see the following table) among:
 -  Speaker volume (Parameter that can be adjusted only with active audio);
 -  Image brightness;
 -  Image contrast;
 -  Image colour.

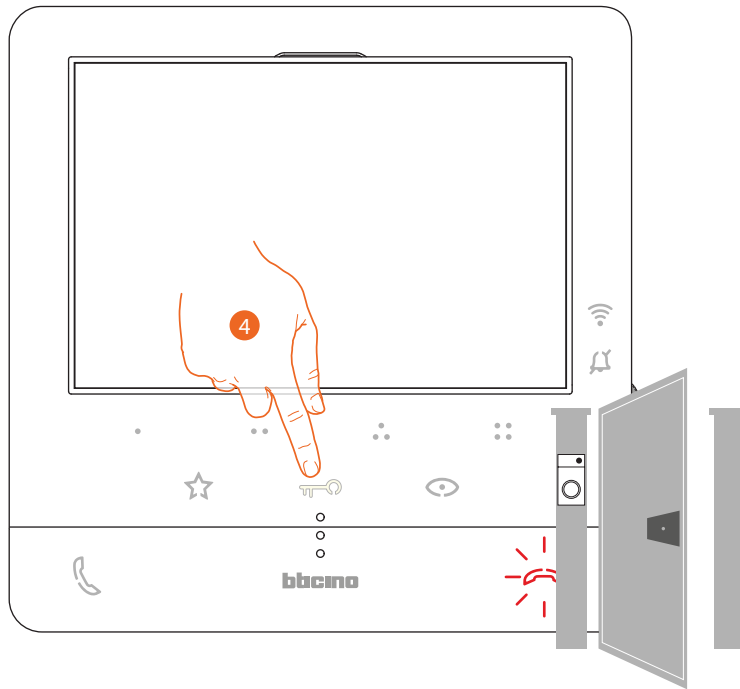

4. Touch to open the main Entrance Panel door lock

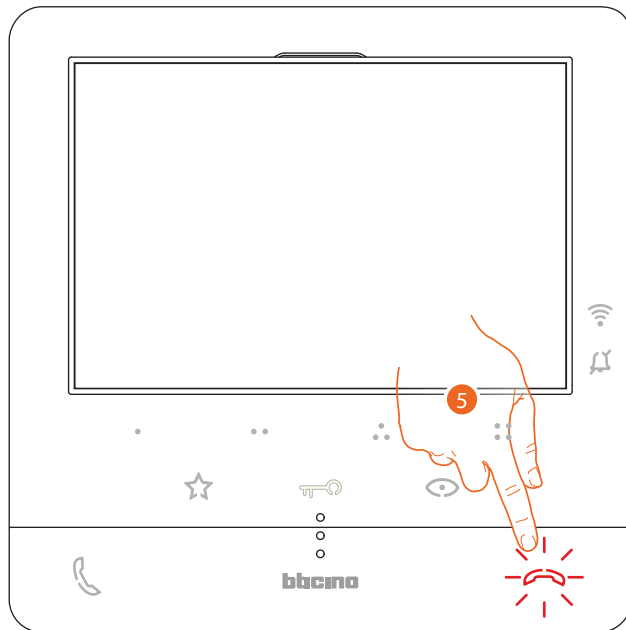

5. Touch to end the call.

Classe100 X16E

User and installation manual

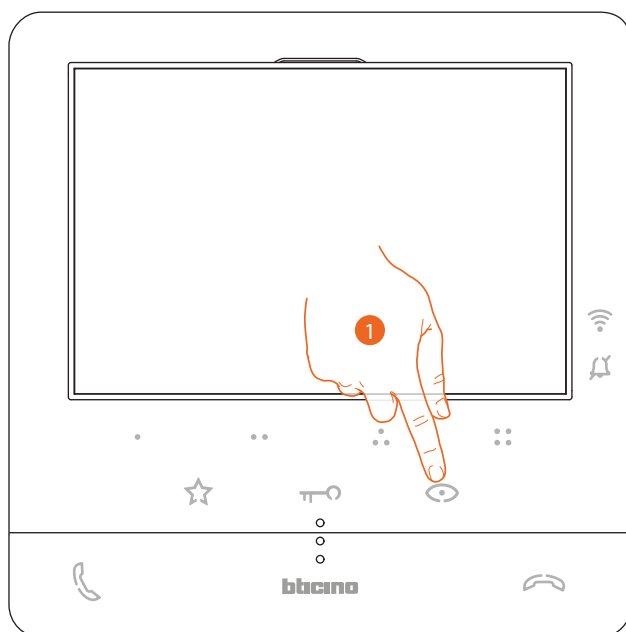

1. Touch to display the Entrance Panels or the cameras in your system.

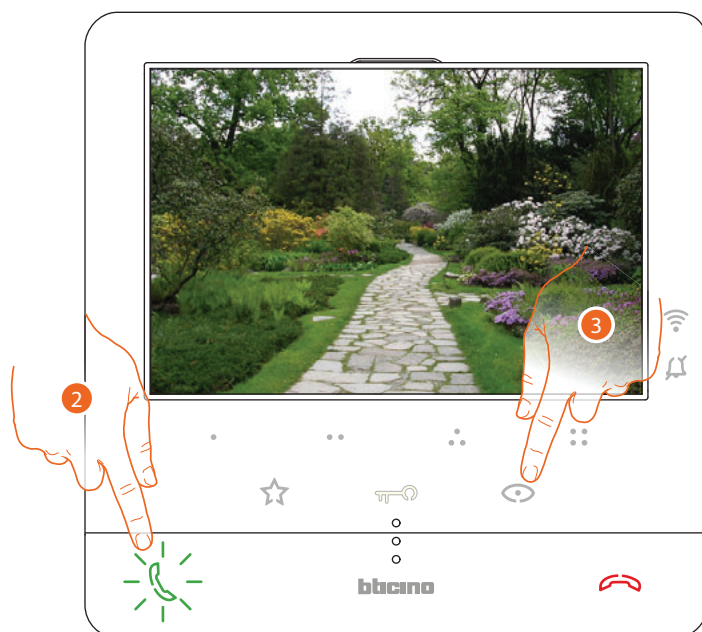

2. If necessary, touch to activate the audio communication

ENGINEERING
TOMORROW



TPOne-M

Electronic Programmable Room Thermostat
including Domestic Hot Water Timer

Quick Guide **GB**

Guide rapide **FR**

Kurzanleitung **DE**

Guía rápida **ES**

Guida rapida **IT**

Hızlı Kılavuz **TR**

Hurtig Guide **DK**

Full product instructions can be found at:

[FR] Des instructions complètes des produits sont consultables à :
 [DE] Die vollständigen Produktinformationen können abgerufen werden auf:
 [ES] Las instrucciones completas de producto se pueden encontrar en:
 [IT] Le istruzioni complete del prodotto sono disponibili all'indirizzo:
 [TR] Ürünle ilgili tüm talimatlar şurada bulunabilir:
 [DK] Der findes en fuld produktvejledning på:

www.guides-tpone.danfoss.com

ErP Class		
The products represented within this document are classified according to, and allow completion of, the Energy Related Product (ErP) Directive System Package fiche and the ErP system data label. ErP Labelling obligation is applicable from 26th September 2015.		
ERP Class	Product Function and ErP Description	Additional efficiency gain
IV	<p>TPI Room Thermostat, for use with on/off output heaters</p> <p>An electronic room thermostat that controls both thermostat cycle rate and in-cycle on/off ratio of the heater proportional to room temperature. TPI control strategy reduces mean water temperature, improves room temperature control accuracy and enhances system efficiency.</p> <p>[FR] Thermostat d'ambiance TPI, à utiliser avec des radiateurs à sortie de type marche/arrêt [DE] TPI-Raumthermostat zur Verwendung mit Ein-/Aus-Ausgangsheizsystemen [ES] Termostato de ambiente TPI, para uso con calentadores de encendido y apagado según demanda [IT] Termostato d'ambiente con funzione TPI, destinato all'uso con apparecchi di riscaldamento con uscita ad accensione/spengimento [TR] Açma/kapama çıkışlı ısıtıcılarla kullanım için TPI Oda Termostatı [DK] TPI-rumtermostat, til anvendelse sammen med til/fra-effektvarmere</p>	2%

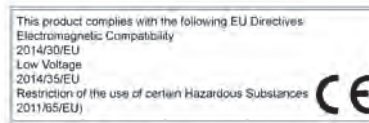

Danfoss can accept no responsibility for possible errors in catalogues, brochures, and other printed material. All trademarks in this material are property of the respective companies. Danfoss and the Danfoss logotype are trademarks of Danfoss A/S. All rights reserved.

Installation Instructions

Please note: This product should only be installed by a qualified electrician or competent heating installer and should be in accordance with local wiring regulations.

[FR] Remarque : ce produit doit être installé exclusivement par un électricien qualifié ou un chauffagiste compétent et doit être conforme à la version en vigueur des réglementations de câblage locales.

[DE] Bitte beachten: Dieses Produkt darf nur von einer Elektrofachkraft oder einem qualifizierten Heizungsinstallateur gemäß der aktuellen Ausgabe der VDE-Elektroinstallationsrichtlinien installiert werden.

[ES] Nota: La instalación de este producto solo puede ser llevada a cabo por electricistas cualificados o instaladores de calefacción formados, de conformidad con la normas de cableado locales.

[IT] NB: questo prodotto deve essere installato solo da un elettricista qualificato o da un installatore riscaldamento competente, in conformità delle norme di cablaggio locali.

[TR] Lütfen Dikkat: Bu ürün yalnızca yetkili bir elektrikçi ya da yetkin bir ısıtma kurulumcusu tarafından kurulmalı ve elektrik tesisatı düzenlemelerinin geçerli sürümüne uygun olmalıdır.

[DK] Bemærk: Dette produkt må kun installeres af en autoriseret elektriker eller en faglært varmeinstallatør og skal overholde de lokale regler og bestemmelser vedrørende.

Thermostat or Remote Room Sensor positioning:

[FR] Positionnement d'un thermostat ou d'une sonde d'ambiance à distance :

[DE] Positionierung des Thermostats oder Raumfernfühlers:

[ES] Colocación del termostato o del sensor de ambiente remoto:

[IT] Posizionamento termostato o sensore ambiente remoto:

[TR] Termostat veya Uzak Oda Sensörünü konumlandırma:

[DK] Placering af termostat eller ekstern rumføler:

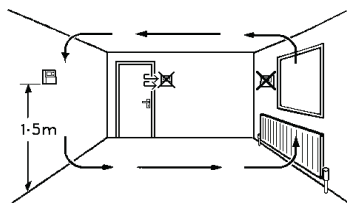

Mounting

[FR] Montage

[IT] Montaggio

[DE] Montage

[TR] Montaj

[ES] Montaje

[DK] Montering

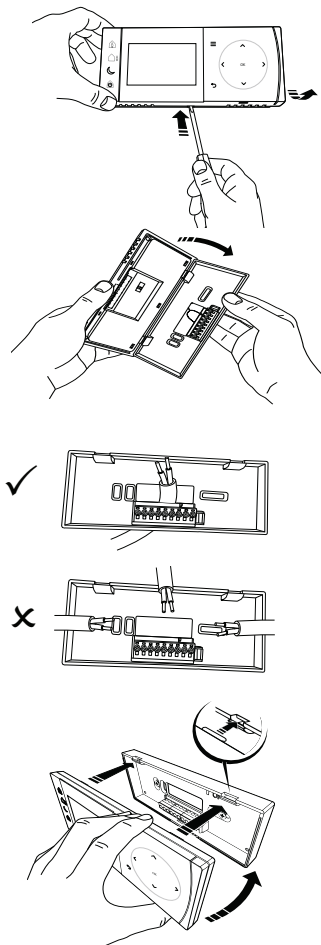

Wiring

[FR] Câblage	[IT] Cablaggio
[DE] Verdrahtung	[TR] Elektrik şebekesi
[ES] Alambrado	[DK] Ledningsføring

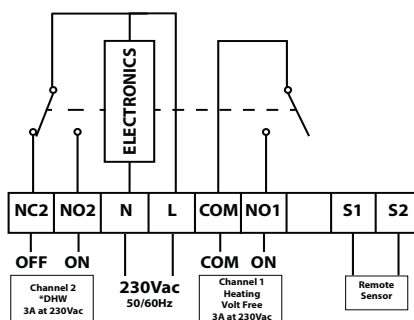

* Domestic hot water, optional timed output only

[FR] Eau chaude sanitaire, sortie programmée optionnelle uniquement
[DE] Trinkwarmwasser, optional nur mit zeitlich gesteuerter Leistung
[ES] Agua caliente sanitaria, solo salida programada opcional
[IT] Solo acqua calda sanitaria, uscita temporizzata opzionale
[TR] Sadece evsel sıcak su, isteğe bağlı zamanlı çıkış
[DK] Kun varmt brugsvand, valgfri tidsindstillet udgang

Remote sensor inputs

[FR] Entrées de capteurs à distance	[IT] Ingressi sensore remoto
[DE] Eingang für entfernte Sensoren	[TR] Oda Sensör Bağlantıları
[ES] Entrada para sensor externo	[DK] Ekstern sensorindgang

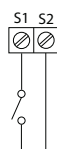
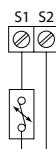

Remote room or limit sensor

[FR] Capteur d'ambiance à distance ou pour capteur de limite
[DE] Fernfühler oder Grenzwertsensor
[ES] Sensor externo de ambiente o sensor de limite de temperatura
[IT] Sensore limite o ambiente remoto
[TR] Oda sensörü veya limit sensörü
[DK] Ekstern rumssensor eller grænseføler

Window switch contact

[FR] Interrupteur de contact de fenêtre
[DE] Fensterschalterkontakt
[ES] Contacto de interruptor de ventana
[IT] Contatto finestra
[TR] Pencere anahtarı kontağı
[DK] Vindueskontakt

User Interface

[FR]	Interface utilisateur	[IT]	Interfaccia utente
[DE]	Bedienoberfläche	[TR]	Kullanıcı Arabirimi
[ES]	Interfaz de usuario	[DK]	Brugergrænseflade

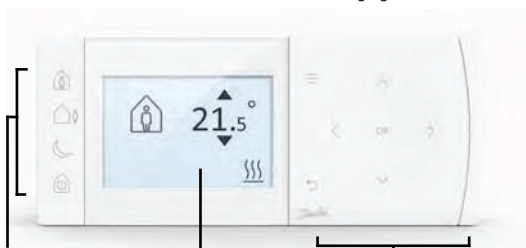

Comfort modes
 [FR] Modes de confort
 [DE] Komfortmodi
 [ES] Modos confort
 [IT] Modalità comfort
 [TU] Konfor modu
 [DK] Komforttilstande

Display
 [FR] Affichage
 [DE] Display
 [ES] Pantalla
 [IT] Display
 [TU] Ekran
 [DK] Display

Navigation
 [FR] Navigation
 [DE] Menü
 [ES] Navegación
 [IT] Navigazione
 [TU] Navigasyon
 [DK] Navigation

	Home	- Accueil - Zu Hause - En Casa	- In Casa - Evde - Hjemme
	Away	- Absence - Abwesend - Ausente	- Fuori Casa - Dışarıda - Ikke til stede
	Asleep	- Nuit - Schlafend - Dormido	- Addormentato - Uyku - Sover
	Standby	- Veille - Standby - En Espera	- Standby - Bekleme - Standby
	Menu	- Menu - Menü - Menü	- Menu - Menüsü - Menu
	Select / Confirm	- Sélectionner/ - confirmer - Auswählen/ - Bestätigen - Seleccionar/ - Confirmar	- Selezionare/ - Confermare - Seç / Onayla - Vælg/bekræft
	Menu Back	- Retour au menu - Menü Zurück - Menü atrás	- Menu indietro - Menüye Geri Dön - Menu tilbage
	Navigation	- Navigation - Menü - Navegación	- Navigazione - Navigasyon - Navigation

Display

[FR] Affichage	[IT] Display
[DE] Display	[TR] Ekran
[ES] Pantalla	[DK] Display

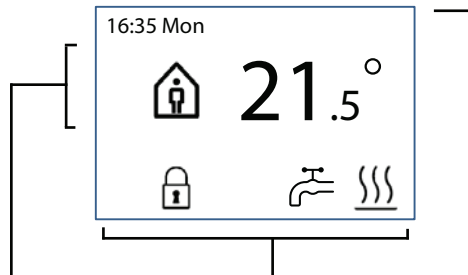

Info & Settings



[FR] Informations et réglages
[DE] Info & Einstellungen
[ES] Información y ajustes
[IT] Info e impostazioni
[TU] Bilgi ve Ayarlar
[DK] Info & indstillinger

Status Icons

[FR] Icônes d'état
[DE] Statussymbole
[ES] Iconos de estado
[IT] Icone di stato
[TU] Durum Simgeleri
[DK] Statusikoner

Dates & Warnings

[FR] Dates et avertissements
[DE] Daten & Warnmeldungen
[ES] Fechas y advertencias
[IT] Date e avvertenze
[TU] Tarihler ve Uyarılar
[DK] Datoer & advarsler

	Button Lock	- Bouton de verrouillage - Tastensperre - Bloqueo del botón	- Blocco pulsanti - Buton Kilidi - Tastatur Lås
	Heat Calling	- Demande de chaleur - Wärmeanforderung - Solicitud de calor	- Calling calore - Isı Arama - Varmeaktivering
	Hot Water	- Eau chaude - Warmwasser - Agua caliente	- Acqua calda - Sıcak Su - Varmt vand

Setup Wizard

[FR]	Assistant de configuration	[IT]	Configurazione guidata
[DE]	Einrichtungsassistent	[TR]	Kurulum Sihirbazı
[ES]	Asistente de configuración	[DK]	Installationsguide

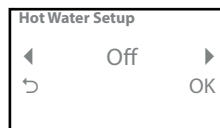
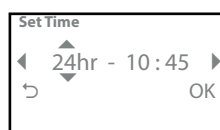
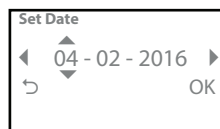
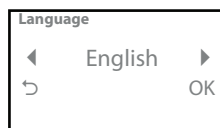
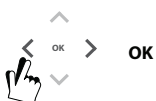

READY

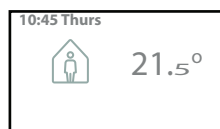

Set Temperatures

[FR]	Réglage des températures	[IT]	Impostazione temperatura
[DE]	Temperaturen einstellen	[TR]	Sıcaklık Ayarlama
[ES]	Ajuste de temperaturas	[DK]	Indstilling af temperaturer

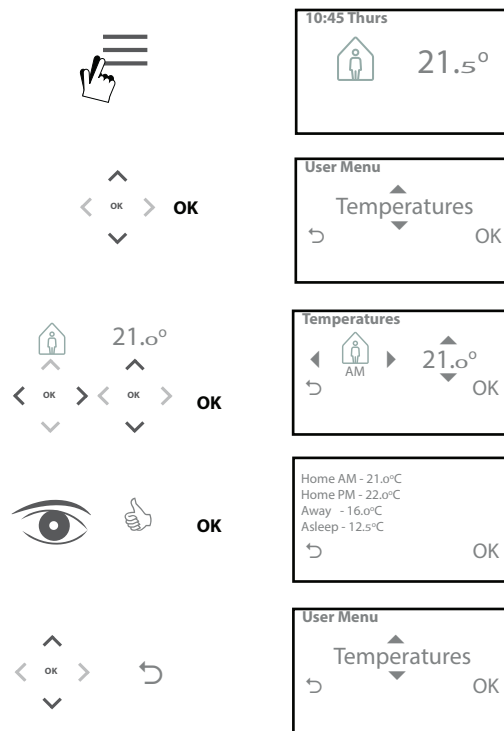

Setup Schedule

[FR]	Planning de programmation	[IT]	Programma di setup
[DE]	Einrichtungsplan	[TR]	Kurulum Programı
[ES]	Configuración de la programación	[DK]	Opsætning af tidsplan

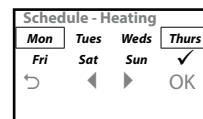
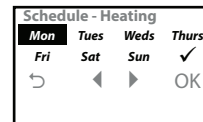
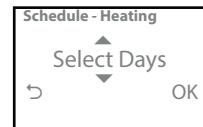
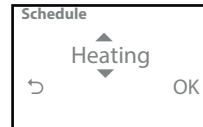
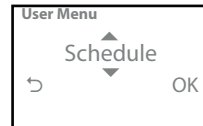
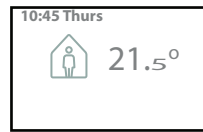

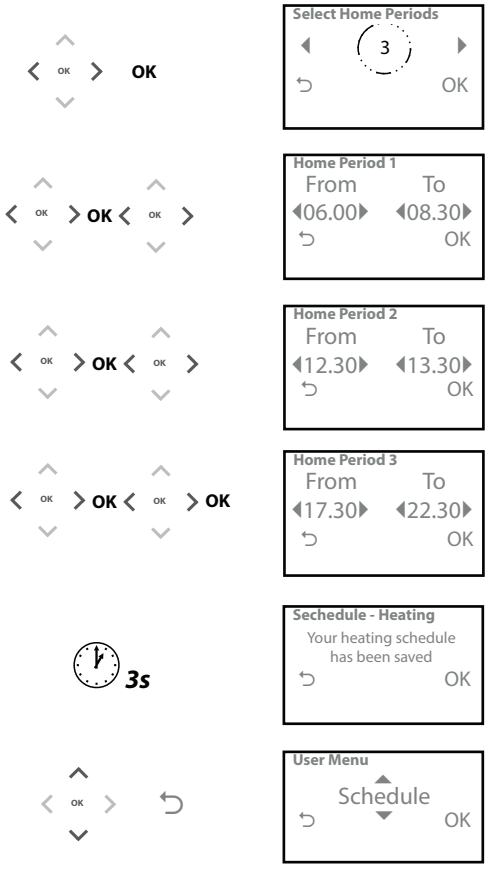

User Menu

[FR]	Menu utilisateur	[IT]	Menu utente
[DE]	Benutzermenü	[TR]	Kullanıcı Menüsü
[ES]	Menú de usuario	[DK]	Brugermenu
Hot Water	- Eau chaude - Warmwasser - Agua caliente	- Acqua calda - Sıcak Su - Varmt vand	
Click & Save	- Cliquer et économiser - Klicken & Sparen - Clic para ahorrar	- Click e risparmia - Tıkla & Kaydet - Klik og spar	
Heating Mode	- Mode de chauffage - Heizbetriebe - Modo Calefacción	- Modalità de Riscald - Isıtma Modu - Varmestyring	
Schedule	- Programme - Zeitplan - Programación	- Pianificazione - Plan - Program	
Temperatures	- Températures - Temperaturen - Temperaturas	- Temperature - Sıcaklıklar - Temperaturer	
Holiday	- Vacances - Ferien - Vacaciones	- Vacanza - Tatil - Ferie	

User Settings

[FR]	Réglages utilisateur	[IT]	Impostaz. utente
[DE]	Benutzereinstellungen	[TR]	Kullanıcı Ayarları
[ES]	Ajustes de usuario	[DK]	Brugerindstillinger

Set Date	- Réglage date - Einstellen des Datums - Configuración de fecha	- Imposta data - Tarihi Ayarlayın - Indstil dato
Set Time	- Réglage heure - Einstellen der Zeit - Configuración de hora	- Imposta ora - Saati Ayarlayın - Indstil klokkeslæt
Button Click	- Bouton de sélection - Schaltflächen - Clic del botón	- Pulsante di Clic - Tikla Butonu - Tastatur Klik
Backlight	- Rétroéclairage - Hintergrundbeleuchtung - Retroiluminación	- Retroilluminazione - Arka Işık - Baggrundsbelysning
Temperature Scale	- Échelle de température - Temperaturbereich - Escala de temperatura	- Scala della temperatura - Sıcaklık Skalası - Temperatur enhed
Language	- Langue - Sprache - Idioma	- Lingua - Dil - Sprog
User Reset	- Réinitialisation - Reset durch Benutzer - Reinicio del usuario	- Reset utente - Kullanıcı Sıfırlama - Bruger reset
Information	- Information - Infos - Información	- Informazioni - Bilgi - Information

Installer Settings

[FR]	Réglages installateur	[IT]	Impostazioni di installazione
[DE]	Installateureinstellungen	[TR]	Kurulumcu Ayarları
[ES]	Ajustes del instalador	[DK]	Installatørindstillinger

Hot Water Setup	- Configuration Eau Chaude - Warmwasser Einstellung - Configuración Agua Caliente	- Configurazione Acqua Calda - Sıcak Su Kurulumu - Opsætning af Varmt Vand
Control Type	- Type de contrôle - Regelungstyp - Tipo de Control	- Tipo di Controllo - Kontrol Tipi - Reguleringstyp
Start-up Method	- Méthode de démarrage - Aufheizverfahren - Método de arranque	- Tipo di avvio riscald - Başlatma Yöntemi - Opvarmningsmetode
Temperature Limits	- Limites de température - Temperaturgrenzen - Límites de temperatura	- Limiti temperatura - Sıcaklık Limitleri - Temperaturgrænser
Frost Protect	- Protection contre le gel - Frostschutz - Protección antiescarcha	- Protezione antigelo - Donma Koruması - Frostbeskyttelse
Temperature Override	- Surpassement - Temp.übersteuerung - Anulación de temperatura	- Cambio manuale temp. - Sıcaklığı Geçersiz Kıl - Manuelle temp. grænser
Daylight Saving	- Heure d'été - Sommerzeit - Horario de verano	- Ora legale - Yaz Saati - Sommertid
Button Lock	- Bouton de verrouillage - Tastensperre - Bloqueo del botón	- Blocco pulsanti - Buton Kilidi - Tastatur Lås
Display Idle Mode	- Mode écran de veille - Display Ruhemodus - Pantalla en modo Reposo	- Modalità display inattivo - Görüntü Bekleme Modu - Inaktivt display
External Sensor	- Sonde externe - Externer Temperaturfühler - Sensor externo	- Sensore esterno - Harici Sensör - Ekstern føler
Service Interval	- Intervalle de maintenance - Serviceintervall - Intervalo de mantenimiento	- Intervallo di manutenzione - Servis Aralığı - Serviceinterval
Service Demo	- Démo Service - Service-Demo - Demo de mantenimiento	- Demo di servizio - Servis Demosu - Service-demo
Installer Lock	- Verrouillage installateur - Installateursperre - Bloqueo del instalador	- Blocco installatore - Kurulumcu Kilidi - Installatørlås
Installer Reset	- Réinitialisation - Installateur Reset - Reinicio del instalador	- Reset installatore - Kurulumcu Sıfırlaması - Installatør reset

Information and Warnings

[FR]	Informations et avertissements	[IT]	Informazioni e avvertenze
[DE]	Informationen und warnungen	[TR]	Bilgi ve Uyarılar
[ES]	Información y advertencias	[DK]	Information og advarsler

Window Open	- Fenêtre ouverte - Fenster offen - Ventana abierta	- Finestra aperta - Açık Pencere - Åbent vindue
Product Lock	- Verrouillage - Heizungssperre aktiv - Bloqueo del dispositivo	- Prodotto bloccato - Ürün Kilitli - Varmespærring aktiv
Optimised Start	- Démarrage anticipé - Optmierter Start - Inicio optimizado	- Avviamento ottimale - Ideal Başlangıç - Optimeret Start
Delayed Start	- Démarrage retardé - Verzögerter Start - Arranque retardado	- Avviamento ritardato - Geciktirilmiş Başlangıç - Forsinket start
Frost Risk	- Risque de gel - Frostgefahr - Riesgo de congelación	- Rischio di congela - Donma Riski - Risiko for frysning
Low Heat	- Chauffage bas - Heizung ausgefallen - Calefacción baja	- Basso calore - Düşük Sıcaklık - Manglende varme
Service Due	- Interval de service - Service fällig - Revise dispositivo	- Servizio dovuto - Servis Zamanı - Tid til service
Heat Reduced	- Chauffage limité - Heizleistung begrenzt - Calefacción reducida	- Riduzione del riscald. - Sıcaklık Düşümü - Varme begrænset
High Floor Temperature	- Température sol élevée - Hohe Bodentemperatur - Temp de suelo alta	- T. elevata del pavimento - Yüksek Akış Sıcaklığı - Høj gulvtemperatur
Sensor Fail	- Défaut sonde - Fühler ausgefallen - Fallo sensor	- Guasto sensore - Sensör Hatası - Fejl på føler
External Sensor Fail	- Défaut sonde extérieure - Raumfühler ausgefallen - Fallo sensor exterior	- Guasto sens. esterno - Harici Sensör Arızası - Fejl på rumføler
Floor Sensor Fail	- Défaut sonde sol - Bodenfühler ausgefallen - Fallo sensor suelo	- Guasto sens. pavimento - Akış Sensörü Arızası - Fejl på gulvføler



Danfoss Ltd.
Amphill Road
Bedford MK42 9ER

Tel: 01234 364621
Fax: 01234 219705
Email: ukheating@danfoss.com
Website: www.heating.danfoss.co.uk

© Danfoss HS | 06/2016 | VQHSB102 (013R9606)

HELP VIDEOS FOR IDEAL HEATING PRODUCTS

Useful videos including how to top up your boiler can be found on the Ideal boilers website

Visit <https://idealheating.com/support/video-help>

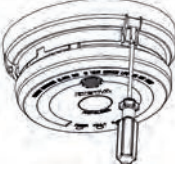
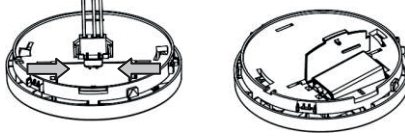
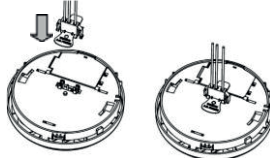
User Information	
Alarm Operation	What to do if the CO alarm sounds
<p>LED indicators</p> <p>Green LED: When connected to the mains supply, the alarm goes through a 40 second initialization routine. After initialization, the GREEN LED remain permanently on indicating normal operation. If GREEN LED flashes every 33 seconds, it indicates the alarm is being powered by the back-up battery.</p> <p>Red LED Flashing: When the alarm senses CO gas, it goes into alarm mode and the RED LED flashes 4 times at 5 second intervals.</p> <p>Yellow LED Flashing: Flashing once every 33 seconds approx. accompanied with two chirps indicates low battery warning. If flashing approximately once every 38 seconds with chirping sound, indicates a fault condition.</p> <p>Alarm Mode</p> <p>In alarm mode, the CO alarm will sound four beeps in quick succession, followed by a 5 second pause. This pattern is then repeated.</p> <p>Test/Silence Button</p> <ul style="list-style-type: none"> Use the Test/Silence button to test the alarm weekly. Please refer to "Testing the Alarm". The Test/Silence button will silence the alarm only if it is in low battery condition. The yellow LED will flash during this condition. The alarm will be silenced for up to 9 hours. To change the battery, please refer to "Replacing the Battery". <p>End of life indication</p> <ul style="list-style-type: none"> The device will give visual and audible warning when it reaches end of life (10 years). The device chirps 3 times every 33 second approx. with yellow LED flashing once. The end of life signal cannot be silenced and the device must be replaced as soon as possible. 	<p>If the CO gas is detected, the alarm will emit a series of four beeps followed by a short pause.</p> <ol style="list-style-type: none"> Alert small children in the home and quickly follow the family escape plan. Keep calm and open all doors and windows to increase the rate of ventilation. Turn off any fuel burning appliances where possible and stop using them. Evacuate the property leaving doors and windows open. Leave immediately and don't waste time getting dressed or picking up valuables. Once outside, go to your selected meeting place and make sure everyone is there. Get medical help for anyone suffering the effects of CO poisoning. Call the appropriate appliance servicing and/or maintenance agency or, where necessary, the relevant fuel supplier on their emergency number. <p>Note: When an alarm sounds, it may be difficult to determine what triggered the alarm, particularly if CO alarms are interlinked with smoke/heat alarms. Therefore, evacuate the property first, then determine the cause and take appropriate action.</p> <p>Note: The CO alarm will return to normal operating mode once the CO gas condition is cleared.</p> <p>Warning: This device alarms only on the detection of carbon Monoxide gas. If ignored, the presence of Carbon Monoxide can be fatal.</p> <p>DANGER: If the alarm sounds, and it is not being tested, it means the unit is sensing Carbon Monoxide gas, THE SOUND OF THE ALARM REQUIRES YOUR IMMEDIATE ATTENTION AND ACTION.</p> <p>Plan of Escape</p> <ul style="list-style-type: none"> It is recommended that a plan of escape is developed and practiced. A floor plan indicating doors and windows should be made and, if possible, that two routes of escape are established.
User Maintenance	
Replacing the Battery	
<p>Warning: Only use the specified batteries (see Product Specification). Use of different batteries may have detrimental effect on the alarm. It is recommended that the battery is replaced when its voltage is low.</p> <ol style="list-style-type: none"> Turn off the electrical supply to the alarms at the consumer unit/fuse box. The green power LED light will go off. To remove the alarm from the base, using a small flat blade screwdriver gently flex the locking clips on the side of the base away from the alarm. The alarm will then come away from the base. See Diagram 8.  <p style="text-align: center;">Diagram 8</p> <ol style="list-style-type: none"> To remove the electrical connector, squeeze the locking arms on the sides while pulling it away from the bottom of the alarm. See Diagram 9. After alarm has been removed, you can open the battery cover and replace with new battery. See Diagram 9.  <p style="text-align: center;">Diagram 9</p> <ol style="list-style-type: none"> After the battery is replaced, close the battery cover and test the alarm by pressing the TEST button. Reconnect the electrical connector, ensuring the orientation is correct and the locking arms snap back into place. See Diagram 10. Fit the alarm body on to the base, ensuring it clips securely into place. 	 <p style="text-align: center;">Diagram 10</p> <ol style="list-style-type: none"> Turn on the electrical supply and the green LED light will come on after the 40 second initialization routine, during which the green light flashes every 3 seconds. Test alarm by pressing the test button. The alarm will sound 4 short beeps – 5 seconds pause, and then repeat until the button is released. <p>It will then go to normal status and the Green LED will always be ON. If there is no sound output when the test button is pushed, the alarm may be defective. See the section: "Trouble Shooting".</p> <p>Caution: Test the alarm for correct operation using the test facility whenever the battery is replaced.</p> <p>Warning: Electricity is dangerous. When replacing the battery, you must make sure the electrical AC power is turned off.</p> <p>Battery</p> <ul style="list-style-type: none"> It is recommended that the battery is replaced annually. This alarm uses a 9 Volt battery. A new battery should last for at least one year under normal operating conditions. This alarm has a low battery monitor which will cause the alarm to "chirp" twice and at the same time the Yellow LED flashes approx. every 33 seconds for a minimum of 7 days when the battery gets low. Replace the battery when this condition occurs. Please refer to "Replacing the Battery". <p>Important: Do not attempt to remove the cover to clean inside. This will affect the warranty.</p>

Testing the Alarm	Important Safety Information
<p>Test the alarm to ensure proper operation.</p> <ol style="list-style-type: none"> Test alarm by pressing and holding the test button until it sounds. The alarm will sound 4 short beeps – 5 seconds pause, and then repeat until the button is released. If multiple alarms are installed within the dwelling, test each alarm. Each alarm should trigger other alarms connected within 10seconds. <p>The alarm must only be tested by pressing the Test/Silence button. Do <u>not</u> ignite combustible materials and start a fire. If no alarm sounds, the unit has a defective battery or other failure. Refer to “Trouble Shooting” section for a solution.</p> <p>Caution: Due to the loudness (85 decibels) of the alarm, always stand an arms-length always from the unit when testing. Erratic or low sound coming from your alarm may indicate a defective alarm.</p> <p>NOTE: WEEKLY TESTING IS REQUIRED</p>	<ul style="list-style-type: none"> The alarm may not alert every household member every time. The alarm horn is loud in order to alert individuals to a potential danger. However, there may be some circumstances where a household member may not hear the alarm (e.g. excessive outdoor or indoor noise, sound sleepers, drug or alcohol usage, the hard of hearing). If you suspect that this alarm may not alert a household member, install and maintain specialty alarms. The alarms have limitations. This alarm is not fool proof and is not warranted to protect lives from exposure to Carbon Monoxide. The alarms are not a substitute for insurance. Occupants should insure their lives and property. In addition, it is possible for the alarm to fail at any time. For this reason, you must test the alarm weekly and replace the unit after 10 years. Test alarm weekly to ensure proper operation by pressing the test button. Do not use any other test method. Do not paint the alarms. Check the alarms on reoccupation of the premises after a vacation.

Maintenance	Carbon Monoxide (CO) Overview
<p>Cleaning</p> <p>The alarm should be cleaned on a monthly basis as a minimum. To do this:</p> <ul style="list-style-type: none"> Turn off the electrical supply to the alarm. Use a vacuum cleaner with the soft brush to vacuum all sides and covers of alarm to remove dust, dirt, and debris. Be sure all the vents are free of debris. Use a damp cloth to clean the alarms cover. Turn the electrical supply to the alarm on. <p>Battery</p> <p>The battery should be replaced annually. See ‘Replacing the Battery’</p>	<p>Carbon monoxide (CO) is an extremely poisonous, colorless, odourless and tasteless gas released by the incomplete combustion of fossil fuels such as natural gas, bottle gas, petrol, diesel, oil, paraffin, wood, coal coke and biofuels. When inhaled, it causes chemical asphyxiation, when CO mixes with the blood and reduces the oxygen carried around the body, particularly to the brain. The following symptoms are typical to CO poisoning and should be discussed with all members of the household.</p> <p>Mild Exposure - Slight headache, nausea, fatigue (flu like symptoms). Medium Exposure - Severe throbbing headache, drowsiness and vomiting. Extreme Exposure - Unconsciousness, cardiorespiratory failure, death.</p>

Important Safety Information
<ul style="list-style-type: none"> This alarm must not be connected to any other manufacturer’s alarms. The alarm must not be exposed to dripping or splashing water. The alarms are designed to give audible warning of a dangerous levels of Carbon Monoxide. The alarms do not detect any other gas. Commonly occurring materials, vapours or gases, e.g. in cleaning fluids, polishes, paints, cooking operations may cause nuisance alarms. Major interferents are acetylene, ethyl alcohol, hydrogen cyanide, hydrogen sulfide, mercaptan, nitrogen dioxide and sulfur dioxide.

Troubleshooting		Problem		Remedy	
The green LED does not light up	<ol style="list-style-type: none"> Check electrical power supply is switched on Check electrical connector is properly connected to alarm If the problem still exists, replace the alarm 	The alarm chirp occurs every 38 seconds approx. at the same time as yellow LED flashes once and goes into fault mode	1. Clean alarm. Refer to “Maintenance”	2. If the problem still exists, replace the alarm	
Alarm does not sound when tested. Note: push test button for at least five seconds while testing!	<ol style="list-style-type: none"> Ensure that the battery and electrical connector is properly connected Clean alarm If the problem still exists, replace the alarm 	The alarm sounds intermittently or when residents are cooking, taking showers, etc. (false alarming)	1. Press test button to pause alarm	2. Open window or fan alarm	3. Clean alarm
The alarm chirps twice every 33 second approx. at the same time as the yellow LED flashes once	The battery needs replacing, refer to “Replacing the Battery”	The alarm sounds different from it is used to. It starts and stops.	4. Clean alarm	5. If the problem still exists, replace the alarm	

Warning: Do not disconnect battery to quiet an unwanted alarm. This will remove your protection. Fan the air or open a window to remove smoke/dust.

Product Specification			
Voltage	220 – 240V @ 50Hz with 9V battery backup	CO Alarm Button – dual function	<ul style="list-style-type: none"> Push to Test Temporarily silence low battery warning
Battery Specification	9V battery DC. Brands: Gold Peak: GP1604S, GP1604A, Raymax: 6LR61 or Duracell: MN1604	Sound Pattern	ISO8201 (BI 0.1s -pause 0.1s -BI 0.1s-pause 0.1s-BI 0.1s-pause 0.1s-BI 0.1s-pause 0.1s with RED LED flash, then repeat)
Battery Life	Over one year	Inter-linkable	up to 12 detectors
Alarm Volume	> 85dB(A) at 1 meter	Operating Conditions	- 10 to +40°C, 30 to 93%RH
Alarm Sensitivity (alarm conditions)	30PPM - Alarms after 120 minutes 50PPM - Between 60 to 90 minutes 100PPM - Between 10 to 40 minutes 300PPM - Less than 3 minutes	Storage Conditions	-20 to +50°C, 10 to 95% RH
		Compliance	BS EN 50291-1:2010+A1:2012
Product Disposal	This alarm come under the Waste Electrical & Electronic Equipment Regulations and must be disposed of in accordance to these Regulations.		



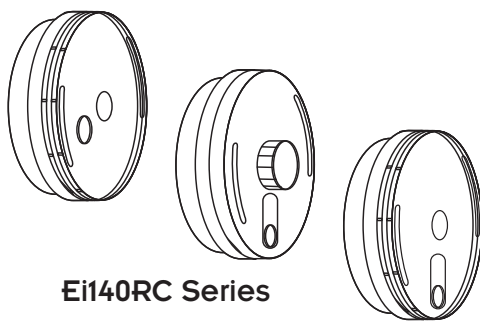

Ei140RC Series

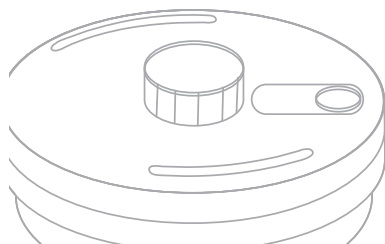

230V~ SMOKE & HEAT ALARMS

with Alkaline Battery Backup

Instruction Manual

Contact Us

Aico Ltd

Mile End Business Park, Maesbury Rd, Oswestry,
Shropshire SY10 8NN, U.K.

Tel: 01691 664100

www.aico.co.uk

Ei Electronics

Shannon, Co Clare, Ireland.

Tel: 061 471277

www.eielectronics.com

User Section

Introduction to Ei140RC Smoke/Heat Alarms

The Ei140RC series is supplied with an Easi-Fit base that allows very quick and simple installation of the Smoke Alarm, combined with simple detector head removal and replacement. The Easi-Fit base automatically connects both mains power and battery as the detector head slides on to the Easi-Fit base.

Up to 12 Smoke/Heat Alarms can be interconnected so that when one senses fire all the units alarm.

Interconnection can be achieved by hardwire or through a RadioLINK Base, the Ei168RC.

A green LED indicates the presence of mains power. A red LED will flash rapidly in an alarm scenario.

All Alarms feature a combined test/hush button.

The "Test/Hush" button will either silence false alarms or perform a unit self-test.

In "Test" mode the Alarm will perform a self-test and sound the horn.

In "Hush" mode the Alarm will be silenced for a period of approximately ten minutes to overcome false alarm conditions. It will then automatically reset itself.

RF Interconnection

The Ei140RC series may be interconnected with any other Ei Electronics RadioLINK or RadioLINK+ products through fitting onto an Ei168RC RadioLINK Base. This base will enable the Ei140RC series Alarms to communicate RF messages to other Ei Electronics products such as the Ei450 RadioLINK Alarm Controller where you can remotely locate, test and hush your Ei140RC Series Alarms using this wireless controller.

For detailed user instructions on using the RF interconnection base Ei168RC with the Ei140RC series, please consult the Ei168RC instruction manual.

Important Information

Do's	Don'ts
Regularly check green mains indicator is lit	Do not paint your Alarm. Do not allow paint, water or dust to contaminate the Alarm
Test Weekly – See testing and maintenance	Your Alarm is powered by 230VAC. Do not open or insert anything into the Alarm
If nuisance alarms occur – press the test/hush button to silence the Alarm for 10 mins	
Clean your Alarm regularly	
Remove or completely cover your Alarm when decorating to prevent dust or other contamination damaging the unit	

Changing The Battery

1. Switch off mains power to Alarm (green light on cover should go out).
 2. Remove unit as shown in "ALARM REMOVAL" section on page 11.
 3. Locate battery slot in base of Alarm as shown below.
 4. Unclip battery from battery snap connectors.
 5. Connect new battery by clipping back on to battery snap connectors. Use only 9V Alkaline batteries Duracell MN1604, Energizer 522. Other batteries can cause problems.
- We recommend that the "replace by date" on the battery should still have at least 2 years to go. Older batteries will give beeps prematurely.
6. Slide unit back on to the base. A click should be heard as the Alarm engages. (The unit cannot be replaced on the base unless a battery is installed).
 7. Press and hold the test button - horn should sound loudly.
 8. Reinstate mains power to Alarm (green light on cover should come on).

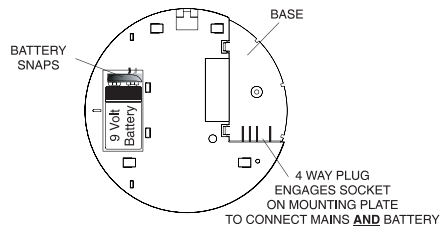

Testing and Maintenance

Check all Alarms weekly, especially after initial installation or re-occupation (e.g. following a holiday)

1. Check that the green mains indicator light is on. (if it is off check circuit breakers, fuses and wiring etc.)
2. Check that the red LED on the cover flashes once every 40 seconds to indicate normal operation – If the memory has been set indicating that the Alarm has been activated in the last 24 hours, the red LED will flash twice every 40 seconds. After 24 hours the memory will be cleared.
3. Press the test button for up to 10 seconds to ensure the sensor chamber, electronics and sounder are working. A red light on the cover, will flash while horn is sounding. The alarm will stop when the button is released. Pressing the test button simulates the effect of smoke or heat during a real fire and is the best way to ensure the Alarm is operating correctly. This action will also clear the memory.

WARNING: DO NOT TEST WITH FLAME

This can set fire to the Alarm and damage the house.

We do not recommend testing with smoke or heat as the results can be misleading unless special apparatus is used.

4. Check for any sign of contamination such as cobwebs or dust and clean the Alarm as described in the "cleaning" section if necessary.

5. Interconnected Alarms only - Test the first unit by pressing the button for 10 seconds. All the units should alarm within 10 seconds of the first horn sounding. The red light on the first unit only will flash about once a second. On releasing the button the local Alarm will stop sounding immediately and the remote Alarms will stop sounding approximately 3 seconds later (if testing using RF interconnection this could take slightly longer). This will verify that the interconnect is working. Check all the other units similarly.

6. Check the functioning of the mains battery back-up directly after installation and then at least yearly as follows:

- Turn off the mains power at the distribution board and check that the green indicator light is extinguished.
- Press the test button and ensure the horn sounds loudly for 10 seconds.

Turn on the mains supply at the distribution board only if the unit passes the above test.

Note: If the mains is disconnected and the battery is almost depleted the unit will beep every 40 seconds for at least 30 days.

7. Monitor the Alarm over a short period of time for any beeps.

Switching off Mains for long periods

If the premises are regularly being left without mains power for long periods the Smoke/Heat Alarms should be removed from their mounting plates to prevent the batteries becoming fully depleted. (This is sometimes done with holiday homes which are only occupied in the Summer).

The Alarms must be re-attached to the mounting plates when the premises are re-occupied.

If the unit is beeping: Before replacing the battery, check that the beeps are not due to one of the following:

- (i) battery snaps not connected properly.
- (ii) On the Optical Smoke Alarm only (Ei146RC) if the unit beeps and the red light does not flash at the same time it indicates a problem with the smoke chamber - see "**Cleaning Your Alarm**" section.

(iii) If the beeps have continued for over 20 minutes (and the other causes of beeps have been ruled out - see "**Troubleshooting**" section) the battery must be replaced.

See "**Changing the Battery**" section.

Cleaning your Alarm

If all of the above possible causes of beeps have been ruled out, but the beeping has still persisted for over 2 hours with the green light on - replace the Alarm. The Smoke / Heat Alarm can be returned to the manufacturer for repair or replacement - see "**Service and Guarantee**" section.

WARNING: Electrical shock hazard. Disconnect the AC mains at the fuse box or circuit breaker powering the Alarm before following the cleaning instructions.

Clean your Alarm regularly, particularly in dusty areas. Use the narrow nozzle attachment of your vacuum cleaner to remove dust, insects and cobwebs from the sides and cover slots where the smoke or heat enters. To clean the cover, wipe with a damp cloth. Dry cover thoroughly with a lint free cloth.

WARNING: Do not paint your Alarm.

Other than the cleaning described above, no other customer servicing of this product is required. Repairs, when needed, must be performed by the manufacturer. All Alarms are prone to dust and insect ingress which can cause nuisance/false alarms or failure to alarm.

In certain circumstances even with regular cleaning, contamination can build up in the smoke sensing chamber causing the Alarm to sound or fail. If this happens the Alarm can be returned to us for servicing or replacement. Contamination is beyond our control, it is totally unpredictable and is considered normal wear and tear.

For this reason, contamination is not covered by the guarantee and a charge is made for servicing such units.

If you experience persistent nuisance/false alarms it may mean that the environment may not be suitable for your particular Alarm type.

Nuisance / False Alarms

When sure that it is just a nuisance/false alarm, simply press the test/silence button briefly on the Alarm to silence the unit for 10 minutes.

If, when the alarm goes off, there is no sign of smoke, heat or noise to indicate that there is a fire, you should get your family into a safe place, before you start investigating.

Check the house carefully in case there is a small fire smouldering somewhere.

Check whether there is some source of smoke or fumes, for example cooking fumes being drawn past the Smoke Alarm by an extractor.

If there are frequent nuisance/false alarms it may be necessary to re-locate the device away from the source of the fumes. If for some reason the Alarm continues to sound without smoke or heat being present (due to insect infestation or contamination build-up for example) the units can be silenced by disconnecting the mains power and removing the unit - see "**ALARM REMOVAL**" section - page 11 (Installer section).

If cleaning the Alarm does not correct the problem it can be returned to the manufacturer for repair or replacement - see "Service and Guarantee" section.

Silence Feature

All the Smoke Alarms have a combined Test/Silence Button to help you control nuisance/false alarms.

1. To silence a nuisance/false alarm, press the Test/Silence Button located on the cover. The Alarm will automatically switch to a reduced sensitivity condition for a 10 minute period (very large levels of smoke from a nearby fire will override the silence period).

The unit will flash the red light every 10 seconds (instead of the normal 40 seconds) to indicate the sensitivity is reduced.

On interconnected Alarms, pressing the Test/Silence Button on the one sensing smoke (i.e. the one with the red light flashing every second) will silence all alarms.

Pressing the Silence Button on any other Alarm will not silence the alarm.

2. The unit will reset to normal sensitivity at the end of the silenced period.

Planning Your Escape Route

Use the Smoke / Heat Alarm Test Buttons to familiarise your family with the Alarm sound and to practice fire drills regularly with all family members. Draw up a floor plan that will show each member at least 2 escape routes from each room in the house.

Children tend to hide when they don't know what to do. Teach children how to escape, open windows, and use roll up fire ladders and stools without adult help. Make sure they know what to do if the alarm goes off.

1. Check room doors for heat or smoke. Do not open a hot door. Use an alternate escape route. Close doors behind you as you leave.

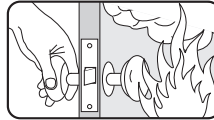

2. If smoke is heavy, crawl out, staying close to floor. Take short breaths, if possible, through a wet cloth or hold your breath. More people die from smoke inhalation than from flames.



3. Get out as fast as you can. Do not stop for packing. Have a prearranged meeting place outside for all family members. Check everybody is there.



4. Call the Fire Brigade immediately on a mobile phone or from a neighbour's house. Make sure to call the Brigade for all fires no matter how small - fires can suddenly spread. Also call the Brigade even if the alarm is automatically transmitted to a remote manned centre - the link may have failed.



5. **NEVER** re-enter a burning house.

Limitations of Smoke / Heat Alarms

Smoke / Heat Alarms have significantly helped to reduce the number of fire fatalities in countries where they are widely installed.

However independent authorities have stated that they may be ineffective in some circumstances. There are a number of reasons for this:

- NOTE: Constant exposure to high or low temperatures or high humidity may reduce the life of the battery.
- Smoke / Heat Alarms will not detect fire if sufficient smoke / heat does not reach the Alarm. Smoke / heat may be prevented from reaching the Alarm if the fire is too far away, for example, if the fire is on another floor, behind a closed door, in a chimney, in a wall cavity, or if the prevailing air draughts carry the smoke / heat away. Installing Smoke / Heat Alarms on both sides of closed doors and installing more than one Smoke

/ Heat Alarm as recommended in the 'INSTALLER INSTRUCTIONS' section significantly improves the probability of early detection.

- The Alarm may not be heard.
- A Smoke / Heat Alarm may not wake a person who has taken drugs or alcohol.
- Smoke / Heat Alarms may not detect every type of fire to give sufficient early warning.
- Smoke / Heat Alarms don't last indefinitely. For example if there is a build up of contamination, performance will be impaired.

It is recommended that the Smoke / Heat Alarms are replaced after 10 years as a precaution.

Service and Guarantee

If your Alarm fails to work after you have carefully read all the instructions, checked the unit has been installed correctly, and is receiving AC power (green light on) contact Customer Assistance at the address given at the end of this leaflet. If it needs to be returned for repair or replacement put it in a padded box and send it to "Customer Assistance and Information" at the nearest address given on the Alarm or in this leaflet. Do not snap on to the mounting plate as this connects the battery and the unit may beep or alarm in the post. State the nature of the fault, where the Alarm was purchased and the date of purchase.

Ei Electronics guarantees this Alarm for five years from date of purchase against any defects that are due to faulty materials or workmanship. This guarantee only applies to normal conditions of use and service, and does not include damage resulting from accident, neglect, misuse, unauthorised dismantling, or contamination howsoever caused. This guarantee excludes incidental and consequential damage. If this Alarm should become defective within the guarantee period, it can be returned to Ei Electronics, with proof of purchase, carefully packaged, with the problem clearly stated. We shall at our discretion repair or replace the faulty unit.

Do not interfere with the Alarm or attempt to tamper with it. This will invalidate the guarantee, but more importantly may expose the user to shock or fire hazards.

This guarantee is in addition to your statutory rights as a consumer.

Troubleshooting

1. ALARM SOUNDS FOR NO APPARENT REASON:

(1) Identify the alarm source. On interconnected units, the red light on the cover will flash rapidly only on the unit which is the source of the alarm. If an optional Ei1529RC Control Switch or an Ei450 Alarm Controller is installed, press Locate when the system is sounding to identify source of alarm.

(2) Check for fumes, steam etc. from the kitchen or bathroom. Paint and other fumes can cause nuisance/false alarms.

(3) Press the test/silence button to silence the Smoke/Heat Alarm for 10 minutes.

(4) If alarm does not stop, switch off mains and remove unit - see "Important Information" section. (Only remove

the alarm with the red light flashing, the others are probably satisfactory).

2. LOW BATTERY & OTHER BEEPS:

(1) If the battery is correctly connected and the unit has beeped for over 20 minutes the battery is probably depleted. Obtain a new battery, disconnect the mains, then remove the Alarm and replace the depleted battery.

(2) If the Ei146RC beeps without the red light flashing at the same time, the chamber is defective. See 'Cleaning your Alarm' section.

(3) If the green mains light is on and replacing the battery or cleaning the unit has not stopped the beeps, a fault may exist. Disconnect the mains first and replace the unit - see "**Alarm Removal**" section.

3. INTERCONNECTED ALARMS DO NOT ALL SOUND:

(1) Hold test button for 10 seconds after first Alarm has sounded to ensure signal is transmitted to all units.

(2) One or more of the connections may not be correctly connected. We recommend you consult a qualified electrician.

The crossed out wheellie bin symbol that is on your product indicates that this product should not be disposed of via the normal household waste stream. Proper disposal will prevent possible harm to the environment or to human health. When disposing of this product please separate it from other waste streams to ensure that it can be recycled in an environmentally sound manner. For more details on collection and proper disposal, please contact your local government office or the retailer where you purchased this product.



 0086	
Ei Electronics, Shannon, Co. Clare, Ireland 08 DoP No.13-0001	
EN14604:2005 + AC:2008 Smoke Alarm Devices: Ei141RC, Ei146RC Fire Safety	
Nominal activation conditions/ sensitivity, response delay (response time) and performance under fire condition	Pass
Operational reliability	Pass
Tolerance to voltage supply	Pass
Response delay and temperature resistance	Pass
Vibration resistance	Pass
Humidity resistance	Pass
Corrosion resistance	Pass
Electrical stability	Pass

	
Heat Alarm Devices: Ei144RC	

The Declaration of Performance No. 13-0001 may be consulted at www.eielectronics.com/compliance

Unity CV2GIP / CV2SVGIP

Decentralised Mechanical Extract Ventilation (dMEV)
User / Homeowner Guide

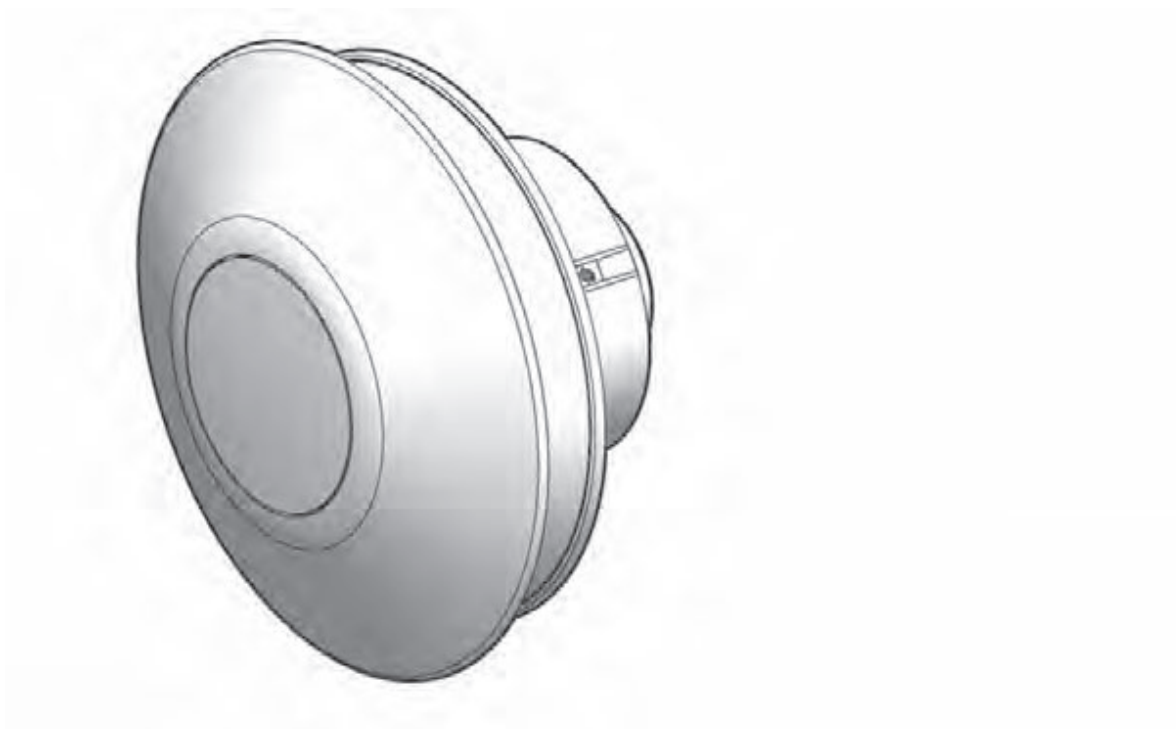

Contents

	User / Homeowner Information	Page
1.	Ventilation in Your Home	3
2.	General Overview	4
3.	Homeowner Controls	6
4.	Servicing / Maintenance	10



WEEE Statement

This product may not be treated as household waste. Instead it should be handed to an appropriate collection point for the recycling of electrical and electronic equipment.

For more detailed information about the recycling of this product, please contact your local council office or your household waste disposal service.



1.0 Ventilation In Your Home

Your home has continuously running ventilation Unity CV2GIP / CV2SVGIP (dMEV) fans installed. This consists of locally sited extract fans that form part of a whole house ventilation approach. These fans extract air on a continual basis from the following areas (defined as wet rooms within Building Regulations) in residential dwellings –

- Kitchen
- Bathroom
- Utility Room
- WC/Cloakroom
- Ensuite Bath/Shower Room

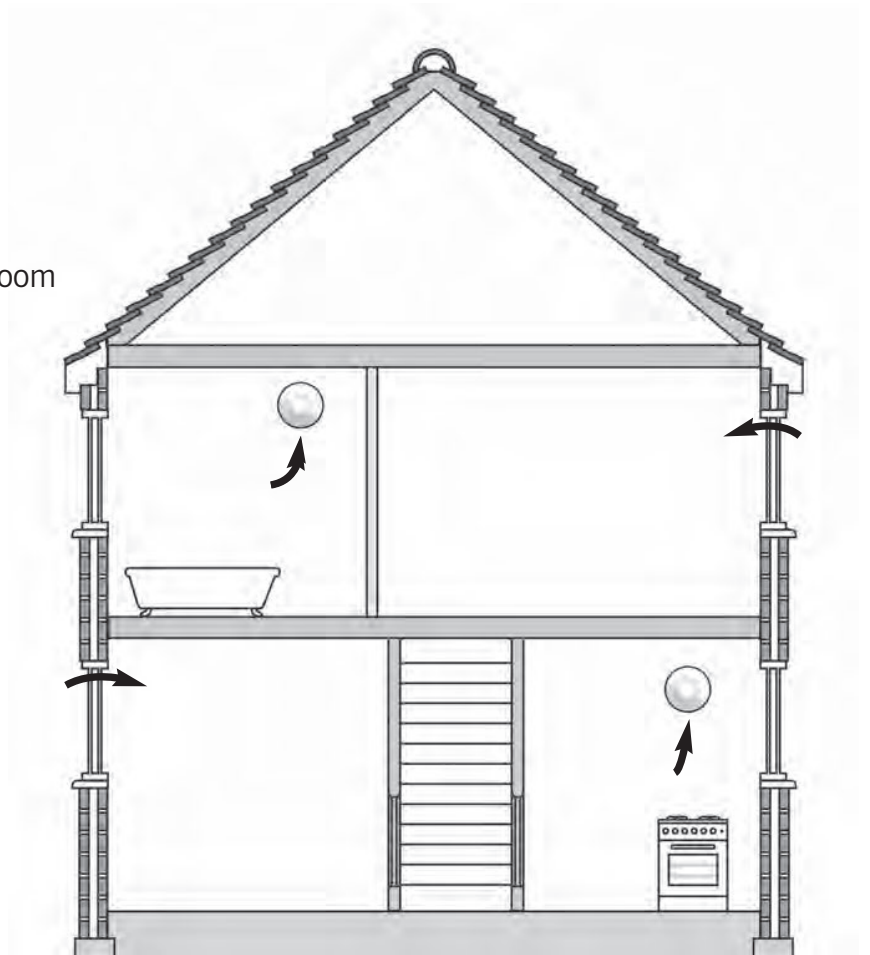

2.0 General Overview

2.1.1 The specific operation of your fan may vary depending on the way it has been installed.

The options are –

Trickle Speed: Operating on a continual basis.

Boost Speed: Activated manually using our GS2 switch or via the room light switch.

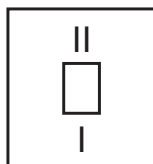

GS2 switch markings - Trickle (I) & Boost (II) Operation

Note: Other manufacturers switches may show different markings.

2.1.2 To maintain a healthy indoor environment the Unity CV2GIP / CV2SVGIP includes SMART technology for Over-run Timer (Greenwood TimerSMART™) and Humidity (Greenwood HumidiSMART™).

2.1.3 **Greenwood TimerSMART™** monitors the length of time that there is an occupancy presence within a wet room (via the 'switch-live') and provides a fixed over-run time period to best match the length of time that the 'switch live' is active (as shown below):

Note: The first 5 minutes will not activate an over-run.

Time 'Switch Live' is Active	Over-run Boost Period
0 – 5 minutes	No over-run
5 – 10 minutes	5 minutes
10 – 15 minutes	10 minutes
15+ minutes	15 minutes

This removes nuisance running noise and unnecessary energy wastage typically associated with traditional timers.

- 
- 2.1.4 **Greenwood HumidiSMART™** monitors the ambient humidity within the wet room environment and looks for short peaks of humidity made by either showering or bathing. This smart technology ensures that your Unity CV2GIP / CV2SVGIP is not on boost for prolonged periods of time, removing nuisance running noise and unnecessary energy wastage typically associated with increases to background humidity which naturally occurs with the changing seasons.
- 2.1.5 To maintain good indoor air quality within the dwelling it is important that the fan remains in operation at all times unless switched off for maintenance. (See section 4.0 Servicing / Maintenance).
- 2.1.6 Depending on when your home was built, background window trickle ventilators may be provided in dry habitable rooms. **Trickle vents should not be installed in the same rooms as the fan, as overall ventilation effectiveness can be reduced.**
- 2.1.7 **Warning:** This appliance can be used by children aged from 8 years and above and persons with reduced physical, sensory or mental capabilities or lack of experience and knowledge if they have been given supervision or instruction concerning use of the appliance in a safe way and understand the hazards involved. Children shall not play with the appliance. Cleaning and user maintenance shall not be made by children without supervision. Always isolate fan from mains supply before cleaning. Do not use solvents to clean this fan.
- 2.1.8 **Siting Notes:** Where an open-flued oil or gas-fuelled appliance is installed in the kitchen, extract ventilation can cause the spillage of flue gases. Care must be taken to ensure ventilation is reduced appropriately, as set out in the Building Regulations. Kitchens with solid-fuel appliances should not have extract fans fitted.
- 2.1.9 The CV2SVGIP fan must only be supplied via Safety Extra Low Voltage (SELV) corresponding to the markings on the appliance.

3.0 Homeowner Controls

3.1.1 Controls

This section shows how to operate the Unity CV2GIP / CV2SVGIP control panel.

3.1.2 Control Panel

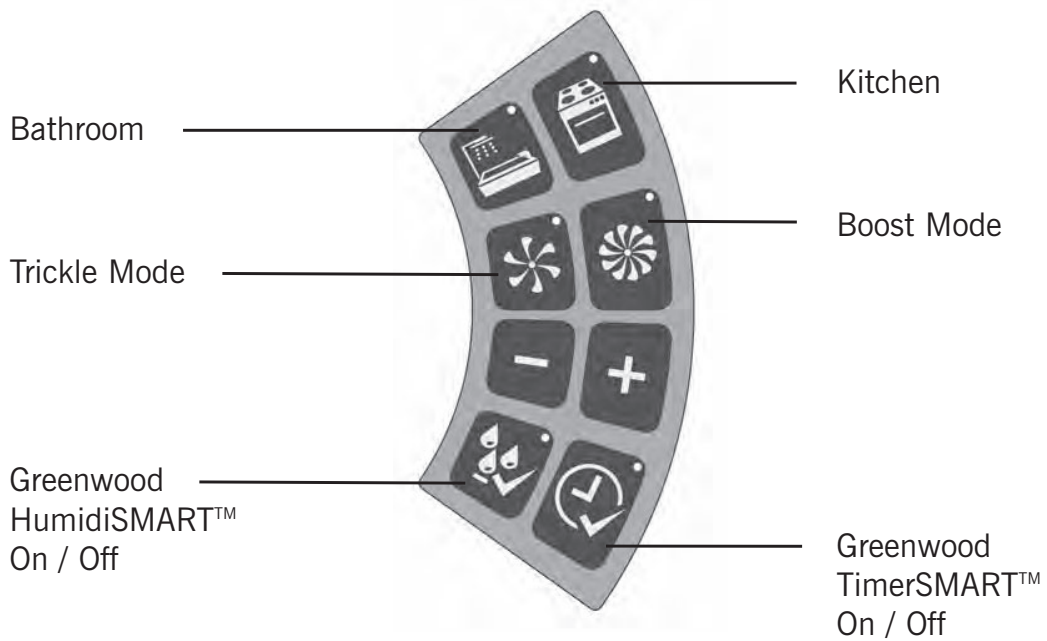

3.1.3 To View Fan Set Up / Status

Press any button to activate the panel. The current fan set up / status will be shown via the green lights.

Example shows: Bathroom setting selected
Boost mode activated
Greenwood HumidiSMART™ feature selected

Note: The Unity CV2GIP / CV2SVGIP is commissioned during installation to provide the correct airflow requirements for your dwelling. Post adjustment of the room setting or airflow speeds is not available.



3.1.4 To Change the Greenwood HumidiSMART™ Setting

The Greenwood HumidiSMART™ monitors the humidity of the extracted air at all times. A rapid rise in humidity from a bath / shower, should be picked up by the sensor and should cause the fan to automatically switch to Boost mode.

When humidity falls below a calculated threshold close to background levels, the fan should return to trickle mode.

To identify current fan status, press any button to activate the panel. Upon identification of control status, either press [] to activate or deactivate the Greenwood HumidiSMART™. Please note the light should come on to indicate that the function is active.

Factory set to OFF

Option's ON / OFF

Note: After approximately 10 seconds of inactivity, the control panel lights should turn off and save selection settings.

Note: This feature can be activated at the same time as the Greenwood TimerSMART™.



3.1.5 To Change the Greenwood TimerSMART™ Setting

The Greenwood TimerSMART™ monitors the length of time the unit has been in boost mode via the Switch Live. Once the Switch Live is deactivated the Greenwood TimerSMART™ over-run period should continue to run the unit for a calculated time if required.

Note: The first 5 minutes should not activate an over-run.

Time 'Switch Live' is Active	Over-run Boost Period
0 – 5 minutes	No over-run
5 – 10 minutes	5 minutes
10 – 15 minutes	10 minutes
15+ minutes	15 minutes

To identify current fan status, press any button to activate the panel. Upon identification of control status, either press [] to activate or deactivate the Greenwood TimerSMART™. Please note the light should come on to indicate that the function is active.

Factory set to OFF

Option's ON / OFF

Note: After approximately 10 seconds of inactivity, the control panel lights should turn off and save selection settings.

Note: This feature can be activated at the same time as the Greenwood HumidiSMART™.



4.0 Servicing / Maintenance

- 4.1.1 The Unity CV2GIP / CV2SVGIP contains a unique backward curved mixed flow impellor that has been designed to reduce against any build up of dirt. **The fan motor has sealed for life bearings, which do not require lubrication.**
- 4.1.2 Periodic cleaning of the fans front cover and casing can be carried out using a soft damp cloth. Care must be taken when wiping around the control panel.
- 4.1.3 **Warning:** The Unity CV2GIP / CV2SVGIP must be isolated from the mains supply before removing the electronics cover. Do not use solvents to clean this fan.
- 4.1.4 Cleaning and user maintenance shall not be made by children without supervision.
- 4.1.5 Please note that your stored fan settings will not be lost during any interruptions to your fan's power supply.

Mira Agile S Eco, Mira Agile S, Mira Agile ERD+
Mira Agile Sense ERD+, Mira Agile Store EV+, Mira Agile EV+

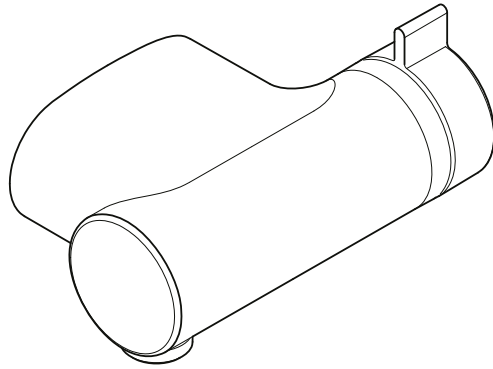

Important Safety Information

WARNING! This shower can deliver scalding temperatures. For continued safe operation, follow all instructions, warnings and cautions contained in this guide and on or inside the shower. Periodic maintenance may be required to keep the product in good working order.

The function of a thermostatic mixing valve is to deliver water consistently at a safe temperature. In keeping with every other mechanism, it cannot be considered as functionally infallible and as such, cannot totally replace a supervisor's vigilance where that is necessary. Provided it is installed, commissioned, operated and maintained within manufacturers recommendations, the risk of failure, if not eliminated, is reduced to the minimum achievable.

PLEASE OBSERVE THE FOLLOWING TO REDUCE THE RISK OF INJURY:

INSTALLING THE SHOWER

1. Installation of the shower must be carried out in accordance with these instructions by qualified, competent personnel. Read all instructions before installing the shower.
2. **DO NOT** install the shower where it may be exposed to freezing conditions. Ensure that any pipework that could become frozen is properly insulated.
3. **DO NOT** perform any unspecified modifications to the shower or its accessories. When servicing only use genuine Kohler Mira replacement parts.
4. If the shower is dismantled during installation or servicing then, upon completion, an inspection must be made to ensure all connections are tight and that there are no leaks.

USING THE SHOWER

5. The shower must be operated and maintained in accordance with the requirements of this guide. Make sure you fully understand how to operate the shower before use, read all instructions and retain this guide for future reference.

6. **DO NOT** switch the shower on if there is a possibility that the water in the shower unit or fittings is frozen.
7. The shower can be used by children aged from 8 years and above and persons with reduced physical, sensory or mental capabilities or lack of experience and knowledge if they have been given supervision or instruction concerning use of the appliance in a safe way and understand the hazards involved. Children must not be allowed to play with the shower.
8. Anyone who may have difficulty understanding or operating the controls of any shower should be attended whilst showering. Particular consideration should be given to the young, the elderly, the infirm or anyone inexperienced in the correct operation of the controls.
9. **DO NOT** allow children to clean or perform any user maintenance to the shower unit without supervision.
10. Always check the water temperature is safe before entering the shower.
11. **DO NOT** adjust the temperature control rapidly while using the shower.
12. Use caution when altering the water temperature while in use, always check the temperature before continuing to shower.
13. **DO NOT** switch the shower off and back on while standing in the water flow.
14. **DO NOT** fit any form of outlet flow control. Only Mira recommended outlet fittings should be used.
15. The showerhead must be descaled regularly. Any blockage of the showerhead or hose may affect showering performance.
16. The water supplies to this product must be isolated if the product is not to be used for a long period of time. If the product or pipework is at risk of freezing during this period they should also be drained of water.
17. When this product has reached the end of its serviceable life, it should be disposed of in a safe manner, in accordance with current local authority recycling, or waste disposal policy.

Operation

Please read **“Important Safety Information”** of this guide before using the shower for the first time.

1 **Single Control** mixers use a single sequential control for on / off and temperature control.

The control operates clockwise in the following sequence:

- Off
- Cold
- Hot (Maximum Preset Temperature)

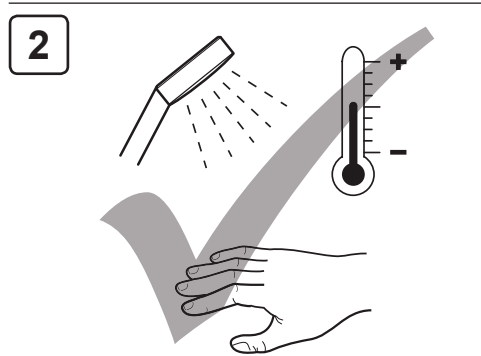
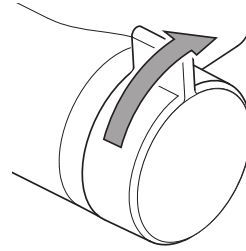

Always check the water temperature before entering shower. The maximum preset temperature (full hot) position can be adjusted, see section **‘Commissioning’**.

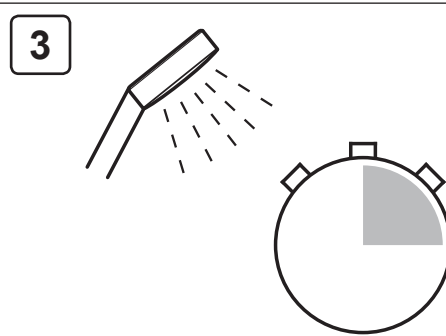

Allow a few seconds for any temperature adjustment to take effect. Allow temperature to stabilise before making a new adjustment.

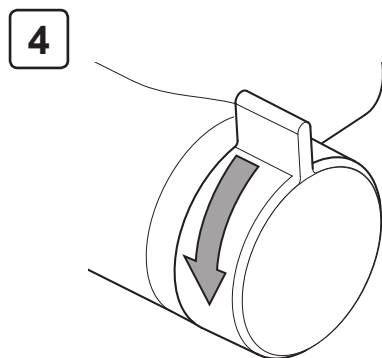

Turn the lever **anti-clockwise** to stop the Shower.

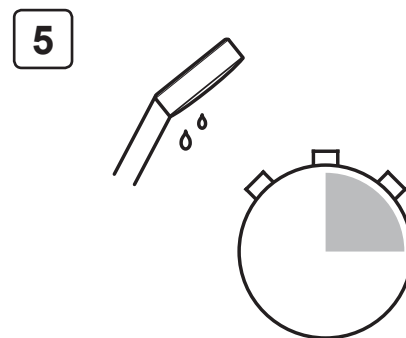

Residual water may drain for a few minutes.

Fault Diagnosis

Only use genuine Kohler Mira replacement parts.

If you require a Mira trained service engineer or agent, please see **“Customer Service”** on the back cover of this guide.

Symptom	Cause	Recommended Action
Only hot or cold water from the shower.	Water inlets are reversed (hot supply to cold supply).	Installation error, supply pipework requires rework.
The shower temperature is either too hot or too cold.	No hot or cold water reaching the shower unit.	Check there is an adequate supply of hot water. See ‘Specifications’ .
		Check the filters for any blockage refer to section ‘User Maintenance’.
		Installation conditions outside operating parameters, refer to sections: ‘Specification’ and ‘Commissioning’ .
		If the temperature is too cold and you have a combination type boiler it may not be producing sufficiently hot water at desired flow rate (refer to ‘Specification’). Make sure flow regulator is fitted. For more information, See ‘Information on Flow Regulators’ or contact Customer Service .
Fluctuating or reduced flow rate.	Hose, shower head or filter blocked.	Remove and clean. Check hose and replace if necessary. Check the filters for any blockage. See ‘User Maintenance’ .
	The inlet pressures are insufficient or unbalanced.	See ‘Specifications’ .
	Air lock or partial blockage in the pipework.	Flush inlet pipes.
	Flow regulator fitted incorrectly.	See Fittings Installation and User Guide.
	Low flow causing combination boiler to cycle.	Incorrect flow reg fitted, blocked showerhead, hose or filters.
Water leaking from the shower head.	Normal for a short period after shut off.	See ‘Specifications’ .
	The inlet pressures exceed the requirements for the shower unit.	See ‘Specifications’ .
	Damage to the shower unit cartridge.	Renew the cartridge.
Movement of valve on the wall.	Pressure spike in water system.	Tighten the retaining screw.

User Manual

GETTING STARTED? EASY.

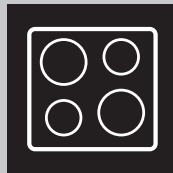

ZGH62414WA
ZGH62414XA
ZGH62414XS

EN User Manual
Hob

GB IE MT

ZANUSSI

SAFETY INFORMATION

Before the installation and use of the appliance, carefully read the supplied instructions. The manufacturer is not responsible for any injuries or damages that are the result of incorrect installation or usage. Always keep the instructions in a safe and accessible location for future reference.

CHILDREN AND VULNERABLE PEOPLE SAFETY

- This appliance can be used by children aged from 8 years and above and persons with reduced physical, sensory or mental capabilities or lack of experience and knowledge if they have been given supervision or instruction concerning the use of the appliance in a safe way and understand the hazards involved.
- Children between 3 and 8 years of age and persons with very extensive and complex disabilities shall be kept away unless continuously supervised.
- Children of less than 3 years of age should be kept away unless continuously supervised.
- Do not let children play with the appliance.
- Keep all packaging away from children and dispose of it appropriately.
- Keep children and pets away from the appliance when it operates or when it cools down. Accessible parts are hot.
- If the appliance has a child safety device, it should be activated.
- Children shall not carry out cleaning and user maintenance of the appliance without supervision.

GENERAL SAFETY

- **WARNING:** The appliance and its accessible parts become hot during use. Care should be taken to avoid touching heating elements.
- Do not operate the appliance by means of an external timer or separate remote-control system.
- **WARNING:** Unattended cooking on a hob with fat or oil can be dangerous and may result in fire.

- NEVER try to extinguish a fire with water, but switch off the appliance and then cover flame e.g. with a lid or a fire blanket.
- CAUTION: The cooking process has to be supervised. A short term cooking process has to be supervised continuously.
- WARNING: Danger of fire: Do not store items on the cooking surfaces.
- Metallic objects such as knives, forks, spoons and lids should not be placed on the hob surface since they can get hot.
- Do not use a steam cleaner to clean the appliance.
- If the supply cord is damaged, it must be replaced by the manufacturer, an authorized Service or similarly qualified persons in order to avoid a hazard.
- Where the appliance is directly connected to the power supply, an all-pole isolating switch with a contact gap is required. Complete disconnection in compliance with the conditions specified in overvoltage category III must be guaranteed. The earth cable is excluded from this.
- When you route the mains cable, make sure that the cable doesn't come into direct contact (for example using insulating sleeving) with parts that can reach temperatures of more than 50°C above room temperature.
- WARNING: Use only hob guards designed by the manufacturer of the cooking appliance or indicated by the manufacturer of the appliance in the instructions for use as suitable or hob guards incorporated in the appliance. The use of inappropriate guards can cause accidents.

SAFETY INSTRUCTIONS

This appliance is suitable for the following markets:



INSTALLATION



WARNING! Only a qualified person must install this appliance.



WARNING! Risk of injury or damage to the appliance.

- Do not install or use a damaged appliance.
 - Follow the installation instructions supplied with the appliance.
 - Keep the minimum distance from other appliances and units.
 - Always take care when moving the appliance as it is heavy. Always use safety gloves and enclosed footwear.
 - Seal the cut surfaces with a sealant to prevent moisture to cause swelling.
 - Protect the bottom of the appliance from steam and moisture.
- Remove all the packaging.

- Do not install the appliance adjacent to a door or under a window. This prevents hot cookware falling from the appliance when the door or the window is opened.
- If the appliance is installed above drawers make sure that the space, between the bottom of the appliance and the upper drawer, is sufficient for air circulation.
- The underside of the appliance can get hot when in use. If an oven has not been fitted underneath the hob and underside of the appliance is accessible and could allow a user or items stored beneath the hob to come in direct contact with the underside of the hob, an intermediate protection panel must be fitted.
- Plywood or kitchen carcass material is acceptable for the panel.
- The panel must be removable for servicing. Screws used to fix the panel must be accessible after installation.

ELECTRICAL CONNECTION



WARNING! Risk of fire and electric shock.

- All electrical connections should be made by a qualified electrician.
- The appliance must be earthed.
- Before carrying out any operation make sure that the appliance is disconnected from the power supply.
- Make sure that the parameters on the rating plate are compatible with the electrical ratings of the mains power supply.
- Make sure the appliance is installed correctly. Loose and incorrect electricity mains cable or plug (if applicable) can make the terminal become too hot.
- Use the correct electricity mains cable.
- Do not let the electricity mains cable tangle.
- Make sure that a shock protection is installed.
- Use the strain relief clamp on the cable.
- Make sure the mains cable or plug (if applicable) does not touch the hot appliance or hot cookware, when you connect the appliance to the near sockets.
- Do not use multi-plug adapters and extension cables.
- Make sure not to cause damage to the mains plug (if applicable) or to the mains cable. Contact our Authorised Service Centre or an electrician to change a damaged mains cable.
- The shock protection of live and insulated parts must be fastened in such a way that it cannot be removed without tools.
- Connect the mains plug to the mains socket only at the end of the installation. Make sure that

there is access to the mains plug after the installation.

- If the mains socket is loose, do not connect the mains plug.
- Do not pull the mains cable to disconnect the appliance. Always pull the mains plug.
- Use only correct isolation devices: line protecting cut-outs, fuses (screw type fuses removed from the holder), earth leakage trips and contactors.
- The electrical installation must have an isolation device which lets you disconnect the appliance from the mains at all poles. The isolation device must have a contact opening width of minimum 3 mm.

GAS CONNECTION



WARNING! These instructions are only valid if the country symbol appears on the appliance. If the symbol does not appear on the appliance, it is necessary to refer to the technical instructions which will provide the necessary instructions concerning modification of the appliance to the conditions of use of the country.

- All gas connections should be made by a qualified person.
- Before installation, make sure that the local distribution conditions (nature of the gas and gas pressure) and the adjustment of the appliance are compatible.
- Make sure that there is air circulation around the appliance.
- The information about the gas supply is on the rating plate.
- This appliance is not connected to a device, which evacuates the products of combustion. Make sure to connect the appliance according to current installation regulations. Pay attention to requirements regarding adequate ventilation.

USE



WARNING! Risk of injury, burns and electric shock.

- Remove all the packaging, labelling and protective film (if applicable) before first use.
- Use this appliance in a household environment.
- Do not change the specification of this appliance.
- Make sure that the ventilation openings are not blocked.

- Do not let the appliance stay unattended during operation.
- Set the cooking zone to "off" after each use.
- Do not put cutlery or saucepan lids on the cooking zones. They can become hot.
- Do not operate the appliance with wet hands or when it has contact with water.
- Do not use the appliance as a work surface or as a storage surface.
- When you place food into hot oil, it may splash.



WARNING! Risk of fire and explosion

- Fats and oil when heated can release flammable vapours. Keep flames or heated objects away from fats and oils when you cook with them.
- The vapours that very hot oil releases can cause spontaneous combustion.
- Used oil, that can contain food remnants, can cause fire at a lower temperature than oil used for the first time.
- Do not put flammable products or items that are wet with flammable products in, near or on the appliance.



WARNING! Risk of damage to the appliance.

- Do not keep hot cookware on the control panel.
- Do not let cookware to boil dry.
- Be careful not to let objects or cookware fall on the appliance. The surface can be damaged.
- Do not activate the cooking zones with empty cookware or without cookware.
- Do not put aluminium foil on the appliance.
- Use only stable cookware with the correct shape and diameter larger than the dimensions of the burners.
- Make sure cookware is centrally positioned on the burners.
- Make sure the flame does not go out when you quickly turn the knob from the maximum to the minimum position.
- Use only the accessories supplied with the appliance.
- Do not install a flame diffuser on the burner.
- The use of a gas cooking appliance results in the production of heat and moisture. Provide good ventilation in the room where the appliance is installed.
- Prolonged intensive use of the appliance may call for additional ventilation, for example

opening of a window, or more effective ventilation, for example increasing the level of mechanical ventilation where present.

- This appliance is for cooking purposes only. It must not be used for other purposes, for example room heating.
- Do not let acid liquids, for example vinegar, lemon juice or limescale remover, touch the hob. This can cause matt patches.
- Discoloration of the enamel or stainless steel has no effect on the performance of the appliance.

CARE AND CLEANING



WARNING! Do not remove the buttons, knobs or gaskets from the control panel. Water may get inside the appliance and cause damage.

- Clean the appliance regularly to prevent the deterioration of the surface material.
- Deactivate the appliance and let it cool down before you clean it.
- Disconnect the appliance from the electrical supply before maintenance.
- Do not use water spray and steam to clean the appliance.
- Clean the appliance with a moist soft cloth. Only use neutral detergents. Do not use any abrasive products, abrasive cleaning pads, solvents or metal objects.
- Do not clean the burners in the dishwasher.

SERVICE

- To repair the appliance contact an Authorised Service Centre.
- Use original spare parts only.

DISPOSAL



WARNING! Risk of injury or suffocation.

- Contact your municipal authority for information on how to discard the appliance correctly.
- Disconnect the appliance from the mains supply.
- Cut off the mains electrical cable close to the appliance and dispose of it.
- Flat the external gas pipes.

PRODUCT DESCRIPTION

COOKING SURFACE LAYOUT

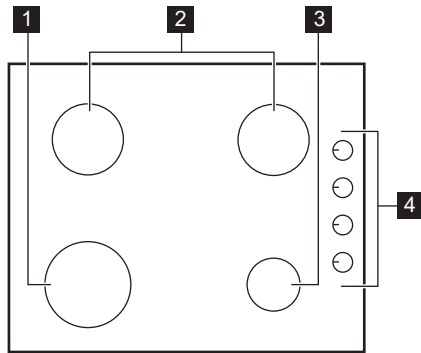

- 1 Rapid burner
- 2 Semi-rapid burner
- 3 Auxiliary burner
- 4 Control knobs

CONTROL KNOB

Symbol	Description
●	no gas supply / off position
🔥	ignition position / maximum gas supply

Symbol	Description
🔥	minimum gas supply

DAILY USE



WARNING! Refer to Safety chapters.

BURNER OVERVIEW

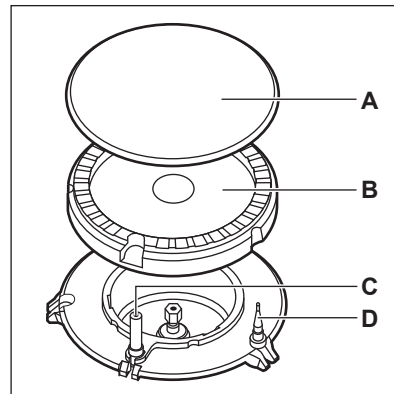



A. Burner cap

- B. Burner crown
- C. Ignition candle
- D. Thermocouple

IGNITION OF THE BURNER

 Always light the burner before you put on the cookware.

 **WARNING!** Be very careful when you use open fire in the kitchen environment. The manufacturer declines any responsibility in case of the flame misuse.

1. Push the control knob down and turn it counterclockwise to the maximum gas supply position ().
2. Keep the control knob pushed for equal or less than 10 seconds. This lets the thermocouple warm up. If not, the gas supply is interrupted.
3. Adjust the flame after it is regular.

 If after some tries the burner does not light, check if the crown and its cap are in correct positions.

 **WARNING!** Do not keep the control knob pushed for more than 15 seconds. If the burner does not light after 15 seconds, release the control knob, turn it into off position and try to light the burner again after minimum 1 minute.



CAUTION! In the absence of electricity you can ignite the burner without electrical device; in this case approach the burner with a flame, turn the control knob counter-clockwise to maximum gas supply position and push it down. Keep the control knob pushed for equal or less than 10 seconds to let the thermocouple warm up.



If the burner accidentally goes out, turn the control knob to the off position and try to light the burner again after minimum 1 minute.



The spark generator can start automatically when you switch on the mains, after installation or a power cut. It is normal.



The hob is supplied with the progressive valves. They make the flame regulation more precise.

TURNING THE BURNER OFF

To put the flame out, turn the knob to the off position  .



WARNING! Always turn the flame down or switch it off before you remove the pans from the burner.

HINTS AND TIPS



WARNING! Refer to Safety chapters.

COOKWARE



CAUTION! Do not use cast iron pans, clay or earthenware pots, grill or toaster plates. The stainless steel can become tarnished if it is too much heated.



WARNING! Do not put the same pan on two burners.



WARNING! Do not put unstable or damaged pots on the burner to prevent spills and injuries.



CAUTION! Make sure that the bottoms of pots do not stand too close to the control knob, otherwise the flame heats the control knob up.



CAUTION! Make sure that pot handles are not above the front edge of the cooktop.



CAUTION! Make sure that the pots are placed centrally on the burner in order to get the maximum stability and a lower gas consumption.

DIAMETERS OF COOKWARE



Use cookware with diameters applicable to the size of burners.

Burner	Diameter of cookware (mm)
Rapid	180 - 260

Burner	Diameter of cookware (mm)
Semi-rapid	120 - 220
Auxiliary	80 - 180

CARE AND CLEANING



WARNING! Refer to Safety chapters.

GENERAL INFORMATION

- Clean the hob after each use.
- Always use cookware with a clean base.
- Scratches or dark stains on the surface have no effect on how the hob operates.
- Use a special cleaner suitable for the surface of the hob.

Stainless steel

- Wash stainless steel parts with water, and then dry them with a soft cloth.
- To remove burnt food, fat and stubborn stains let them soak in a small amount of mild detergent for a few minutes before cleaning.
- Use cleaning products designed specifically for cleaning stainless steel in order to protect the steel surfaces.
- Do not use cleaning products containing corrosive chemicals such as chlorides, do not clean the surface with disinfectants, stain or rust removers and immersion cleaners.

PAN SUPPORTS



The pan supports are not resistant to washing in a dishwasher. They must be washed by hand.

1. Remove the pan supports to easily clean the hob.



Be very careful when you replace the pan supports to prevent the hob top from damage.

2. The enamel coating occasionally can have rough edges, so be careful when you wash the pan supports by hand and dry them. If necessary, remove stubborn stains with a paste cleaner.
3. After you clean the pan supports, make sure that they are in correct positions.
4. For the burner to operate correctly, make sure that the arms of the pan supports are aligned with the centre of the burner.

CLEANING THE HOB

- **Remove immediately:** melted plastic, plastic foil, sugar and food with sugar, otherwise, the dirt can cause damage to the hob. Take care to avoid burns.
- **Remove when the hob is sufficiently cool:** limescale rings, water rings, fat stains, shiny metallic discoloration. Clean the hob with a moist cloth and a non-abrasive detergent. After cleaning, wipe the hob dry with a soft cloth.
- To clean the enamelled parts, caps and crowns, wash them with warm soapy water and dry them carefully before you put them back on.

CLEANING THE SPARK PLUG

This feature is obtained through a ceramic ignition candle with a metal electrode. Keep these components well clean to prevent difficult lighting and check that the burner crown holes are not obstructed.

PERIODIC MAINTENANCE

Speak to your local Authorised Service Centre periodically to check the conditions of the gas supply pipe and the pressure adjuster, if fitted.

TROUBLESHOOTING



WARNING! Refer to Safety chapters.

WHAT TO DO IF...

Problem	Possible cause	Remedy
There is no spark when you try to activate the spark generator.	The hob is not connected to an electrical supply or it is connected incorrectly.	Check if the hob is correctly connected to the electrical supply.
	The fuse is blown.	Make sure that the fuse is the cause of the malfunction. If the fuse is blown again and again, contact a qualified electrician.
The flame extinguishes immediately after ignition.	Burner cap and crown are placed incorrectly.	Place the burner cap and crown correctly.
	Thermocouple is not heated up sufficiently.	After lighting the flame, keep the knob pushed for equal or less than 10 seconds.
The flame ring is uneven.	Burner crown is blocked with food residues.	Make sure that the injector is not blocked and the burner crown is clean.

IF YOU CANNOT FIND A SOLUTION...

If you cannot find a solution to the problem yourself, contact your dealer or an Authorised Service Centre. Give the data from the rating plate. Make sure, you operated the hob correctly. If not the servicing by a service technician or dealer will not

be free of charge, also during the warranty period. The instructions about the Service Centre and conditions of guarantee are in the guarantee booklet.

WWW.ZANUSSI.COM/SHOP



CE

867345007-C-232018

User Manual

GETTING STARTED? EASY.



ZOP37902XU
ZOP37972BK
ZOP37982XK

EN User Manual
Oven

ZANUSSI

SAFETY INFORMATION

Before the installation and use of the appliance, carefully read the supplied instructions. The manufacturer is not responsible for any injuries or damages that are the result of incorrect installation or usage. Always keep the instructions in a safe and accessible location for future reference.

CHILDREN AND VULNERABLE PEOPLE SAFETY

- This appliance can be used by children aged from 8 years and above and persons with reduced physical, sensory or mental capabilities or lack of experience and knowledge if they have been given supervision or instruction concerning the use of the appliance in a safe way and understand the hazards involved.
- Children between 3 and 8 years of age and persons with very extensive and complex disabilities shall be kept away unless continuously supervised.
- Children of less than 3 years of age should be kept away unless continuously supervised.
- Do not let children play with the appliance.
- Keep all packaging away from children and dispose of it appropriately.
- Keep children and pets away from the appliance when it operates or when it cools down. Accessible parts are hot.
- If the appliance has a child safety device, it should be activated.
- Children shall not carry out cleaning and user maintenance of the appliance without supervision.

GENERAL SAFETY

- Only a qualified person must install this appliance and replace the cable.
- **WARNING:** The appliance and its accessible parts become hot during use. Care should be taken to avoid touching heating elements.
- Always use oven gloves to remove or put in accessories or ovenware.

- Before carrying out any maintenance, disconnect the appliance from the power supply.
- Ensure that the appliance is switched off before replacing the lamp to avoid the possibility of electric shock.
- Do not use a steam cleaner to clean the appliance.
- Do not use harsh abrasive cleaners or sharp metal scrapers to clean the glass door since they can scratch the surface, which may result in shattering of the glass.
- If the mains power supply cable is damaged, it must be replaced by the manufacturer, its Authorised Service Centre or similarly qualified persons to avoid an electrical hazard.
- Excessive spillage must be removed before the pyrolytic cleaning. Remove all parts from the oven.
- To remove the shelf supports first pull the front of the shelf support and then the rear end away from the side walls. Install the shelf supports in the opposite sequence.
- The means for disconnection must be incorporated in the fixed wiring in accordance with the wiring rules.

SAFETY INSTRUCTIONS

INSTALLATION



WARNING! Only a qualified person must install this appliance.

- Remove all the packaging.
- Do not install or use a damaged appliance.
- Follow the installation instructions supplied with the appliance.
- Always take care when moving the appliance as it is heavy. Always use safety gloves and enclosed footwear.
- Do not pull the appliance by the handle.
- Keep the minimum distance from other appliances and units.
- Install the appliance in a safe and suitable place that meets installation requirements.
- Make sure that the parameters on the rating plate are compatible with the electrical ratings of the mains power supply.
- Always use a correctly installed shockproof socket.
- Do not use multi-plug adapters and extension cables.
- Make sure not to cause damage to the mains plug and to the mains cable. Should the mains cable need to be replaced, this must be carried out by our Authorised Service Centre.
- Do not let mains cables touch or come near the appliance door, especially when the door is hot.
- The shock protection of live and insulated parts must be fastened in such a way that it cannot be removed without tools.
- Connect the mains plug to the mains socket only at the end of the installation. Make sure that there is access to the mains plug after the installation.
- If the mains socket is loose, do not connect the mains plug.
- Do not pull the mains cable to disconnect the appliance. Always pull the mains plug.
- Use only correct isolation devices: line protecting cut-outs, fuses (screw type fuses)

ELECTRICAL CONNECTION



WARNING! Risk of fire and electric shock.

- All electrical connections should be made by a qualified electrician.
- The appliance must be earthed.

- removed from the holder), earth leakage trips and contactors.
- The electrical installation must have an isolation device which lets you disconnect the appliance from the mains at all poles. The isolation device must have a contact opening width of minimum 3 mm.
- Fully close the appliance door, before you connect the mains plug to the mains socket.
- This appliance complies with the E.E.C. Directives.

USE



WARNING! Risk of injury, burns and electric shock or explosion.

- This appliance is for household use only.
- Do not change the specification of this appliance.
- Make sure that the ventilation openings are not blocked.
- Do not let the appliance stay unattended during operation.
- Deactivate the appliance after each use.
- Be careful when you open the appliance door while the appliance is in operation. Hot air can release.
- Do not operate the appliance with wet hands or when it has contact with water.
- Do not apply pressure on the open door.
- Do not use the appliance as a work surface or as a storage surface.
- Open the appliance door carefully. The use of ingredients with alcohol can cause a mixture of alcohol and air.
- Do not let sparks or open flames to come in contact with the appliance when you open the door.
- Do not put flammable products or items that are wet with flammable products in, near or on the appliance.



WARNING! Risk of damage to the appliance.

- To prevent damage or discoloration to the enamel:
 - do not put ovenware or other objects in the appliance directly on the bottom.
 - do not put aluminium foil directly on the bottom of cavity of the appliance.
 - do not put water directly into the hot appliance.
 - do not keep moist dishes and food in the appliance after you finish the cooking.
 - be careful when you remove or install the accessories.

- Discoloration of the enamel or stainless steel has no effect on the performance of the appliance.
- Use a deep pan for moist cakes. Fruit juices cause stains that can be permanent.
- This appliance is for cooking purposes only. It must not be used for other purposes, for example room heating.
- Always cook with the oven door closed.
- If the appliance is installed behind a furniture panel (e.g. a door) make sure the door is never closed when the appliance is in operation. Heat and moisture can build up behind a closed furniture panel and cause subsequent damage to the appliance, the housing unit or the floor. Do not close the furniture panel until the appliance has cooled down completely after use.

CARE AND CLEANING



WARNING! Risk of injury, fire, or damage to the appliance.

- Before maintenance, deactivate the appliance and disconnect the mains plug from the mains socket.
- Make sure the appliance is cold. There is the risk that the glass panels can break.
- Replace immediately the door glass panels when they are damaged. Contact the Authorised Service Centre.
- Be careful when you remove the door from the appliance. The door is heavy!
- Clean regularly the appliance to prevent the deterioration of the surface material.
- Clean the appliance with a moist soft cloth. Only use neutral detergents. Do not use any abrasive products, abrasive cleaning pads, solvents or metal objects.
- If you use an oven spray, follow the safety instruction on it's packaging.
- Do not clean the catalytic enamel (if applicable) with any kind of detergent.

PYROLYTIC CLEANING



WARNING! Risk of Injury / Fires / Chemical Emissions (Fumes) in Pyrolytic Mode.

- Before carrying out a Pyrolytic self-cleaning function or the First Use please remove from the oven cavity:
 - any excess food residues, oil or grease spills / deposits.
 - any removable objects (including shelves, side rails etc., provided with the product)

- particularly any non-stick pots, pans, trays, utensils etc.
- Read carefully all the instructions for Pyrolytic cleaning.
- Keep children away from the appliance while the Pyrolytic cleaning is in operation.
 - The appliance becomes very hot and hot air is released from the front cooling vents.
- Pyrolytic cleaning is a high temperature operation that can release fumes from cooking residues and construction materials, as such consumers are strongly advised to:
 - provide good ventilation during and after each Pyrolytic cleaning.
 - provide good ventilation during and after the first use at maximum temperature operation.
- Unlike all humans, some birds and reptiles can be extremely sensitive to potential fumes emitted during the cleaning process of all Pyrolytic Ovens.
 - Remove any pets (especially birds) from the vicinity of the appliance location during and after the Pyrolytic cleaning and first use maximum temperature operation to a well ventilated area.
- Small pets can also be highly sensitive to the localized temperature changes in the vicinity of all Pyrolytic Ovens when the Pyrolytic self cleaning program is in operation.
- Non-stick surfaces on pots, pans, trays, utensils etc., can be damaged by the high temperature Pyrolytic cleaning operation of all Pyrolytic Ovens and can be also a source for low level harmful fumes.

- Fumes released from all Pyrolytic Ovens / Cooking Residues as described are not harmful to humans, including infants or persons with medical conditions.

INTERNAL LIGHTING



WARNING! Risk of electric shock.

- The type of light bulb or halogen lamp used for this appliance is for household appliances only. Do not use it for house lighting.
- Before replacing the lamp, disconnect the appliance from the power supply.
- Only use lamps with the same specifications.

SERVICE

- To repair the appliance contact an Authorised Service Centre.
- Use original spare parts only.

DISPOSAL



WARNING! Risk of injury or suffocation.

- Disconnect the appliance from the mains supply.
- Cut off the mains electrical cable close to the appliance and dispose of it.
- Remove the door catch to prevent children or pets from becoming trapped in the appliance.

PRODUCT DESCRIPTION

GENERAL OVERVIEW

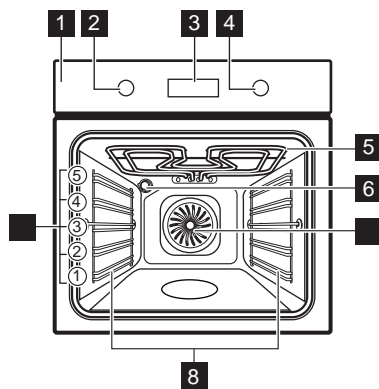

- 1 Control panel
- 2 Knob for the heating functions
- 3 Display
- 4 Control knob (for the temperature)
- 5 Heating element
- 6 Lamp
- 7 Fan
- 8 Shelf support, removable
- 9 Shelf positions

ACCESSORIES

- **Wire shelf**
For cookware, cake tins, roasts.
- **Grill- / Roasting pan**
To bake and roast or as pan to collect fat.
- **Trivet**

For roasting and grilling.



Use the trivet only with the Grill- / roasting pan.

CONTROL PANEL

BUTTONS

Sensor field / Button	Function	Description
—	MINUS	To set the time.
⌚	CLOCK	To set a clock function.
+	PLUS	To set the time.

DISPLAY

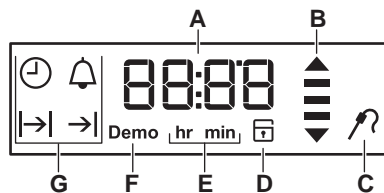

- A. Timer / Temperature
- B. Heat-up and residual heat indicator
- C. Core temperature sensor (selected models only)
- D. Door lock (selected models only)
- E. Hours / minutes
- F. Demo mode (selected models only)
- G. Clock functions

BEFORE FIRST USE



WARNING! Refer to Safety chapters.



To set the Time of day refer to "Clock functions" chapter.

INITIAL CLEANING

Remove all accessories and removable shelf supports from the oven.

Refer to "Care and cleaning" chapter.

Clean the oven and the accessories before the first use.

Put the accessories and the removable shelf supports back to their initial position.

PREHEATING

Preheat the empty oven before first use.

1. Set the function Set the maximum temperature.
2. Let the oven operate for 1 hour.
3. Set the function Set the maximum temperature.
4. Let the oven operate for 15 minutes.
5. Turn off the oven and let it cool down.

Accessories can become hotter than usual. The oven can emit an odour and smoke. Make sure that the airflow in the room is sufficient.

DAILY USE



WARNING! Refer to Safety chapters.







RETRACTABLE KNOBS

To use the appliance press the knob. The knob comes out.

HEATING FUNCTIONS

Oven function	Application
Off position	The oven is off.
True Fan Cooking	To bake on up to three shelf positions at the same time and to dry food. Set the temperature 20 - 40 °C lower than for Conventional Cooking.
Conventional Cooking (Top / Bottom Heat)	To bake and roast food on one shelf position.

Oven function	Application
Moist Fan Baking	This function is designed to save energy during cooking. For the cooking instructions refer to "Hints and tips" chapter, Moist Fan Baking. The oven door should be closed during cooking so that the function is not interrupted and to ensure that the oven operates with the highest energy efficiency possible. When you use this function, the temperature in the cavity may differ from the set temperature. The residual heat is used. The heating power may be reduced. For general energy saving recommendations refer to "Energy Efficiency" chapter, Energy Saving. This function was used to comply with the energy efficiency class according to EN 60350-1. When you use this function the lamp automatically turns off after 30 seconds.

Oven function	Application
 Fast Grilling	To grill flat food in large quantities and to toast bread.
 Turbo Grilling	To roast larger meat joints or poultry with bones on one shelf position. To make gratins and to brown.
 Pizza Setting	To bake pizza. To make intensive browning and a crispy bottom.
 Meat	To prepare very tender and juicy roasts.
 Keep Warm	To keep food warm.
 Defrost	To defrost food (vegetables and fruit). The defrosting time depends on the amount and size of the frozen food.

Oven function	Application
 Pyrolysis	To turn on the pyrolytic cleaning of the oven. This function burns off residual dirt in the oven.

SETTING A HEATING FUNCTION

1. Turn the knob for the heating functions to select a heating function.
2. Turn the control knob to select the temperature.

The lamp turns on when the oven operates.





3. To turn off the oven, turn the knob for the heating functions to the off position.

HEAT-UP INDICATOR

When the oven function operates, the bars in the display  appear one by one when the temperature in the oven increases, and disappear when it decreases.

CLOCK FUNCTIONS

CLOCK FUNCTIONS TABLE

Clock function	Application
 TIME OF DAY	To show or change the time of day. You can change the time of day only when the oven is off.
 DURATION	To set how long the oven works. Use only when a heating function is set.
 END	To set when the oven turns off. Use only when a heating function is set.
 TIME DELAY	Combination of DURATION and END function.

Clock function	Application
 MINUTE MINDER	Use to set a countdown time. This function has no effect on the operation of the oven. You can set the MINUTE MINDER at any time, also if the oven is off.
00:00 COUNT UP TIMER	If you do not set any other clock function the COUNT UP TIMER automatically monitor how long the oven works. It is on immediately when the oven starts to heat. The Count Up Timer cannot be used with the functions: DURATION, END.

SETTING AND CHANGING THE TIME

After the first connection to the mains, wait until the display shows **hr** and "12:00". "12" flashes.

1. Press **+** or **-** to set the hours.
2. Press **⏸** to confirm and set the minutes.

The display shows **min** and the set hour. "00" flashes.

3. Press **+** or **-** to set the current minutes.
4. Press **⏸** to confirm or the set time of day will be saved automatically after 5 seconds.

The display shows the new time.

To change the time of day press **⏸** again and again until the indicator for the time of day **⏸** flashes in the display.

SETTING THE DURATION FUNCTION

1. Set a heating function.
2. Press **⏸** again and again until **→|** starts to flash.
3. Press **+** or **-** to set the minutes and then the hours. Press **⏸** to confirm.

When the set Duration time ends the signal sounds for 2 minutes. **→|** and time setting flash in the display. The oven turns off automatically.

4. Press any button or open the oven door to stop the signal.
5. Turn the knob for the heating functions to the off position.

SETTING THE END FUNCTION

1. Set a heating function.
2. Press **⏸** again and again until **→|** starts to flash.
3. Press **+** or **-** to set the hours and then the minutes. Press **⏸** to confirm.

At the set End time the signal sounds for 2 minutes. **→|** and time setting flash in the display. The oven turns off automatically.

4. Press any button or open the oven door to stop the signal.
5. Turn the knob for the heating functions to the off position.

USING THE ACCESSORIES



WARNING! Refer to Safety chapters.

SETTING THE TIME DELAY FUNCTION

1. Set a heating function.
2. Press **⏸** again and again until **→|** starts to flash.
3. Press **+** or **-** to set the minutes and then the hours for DURATION time. Press **⏸** to confirm.

The display shows flashing **→|**.

4. Press **+** or **-** to set the hours and then the minutes for END time. Press **⏸** to confirm. The display shows **→|→|** and the set temperature.

Oven turns on automatically later on, works for the set DURATION time and stops at the set END time. At the set END time the signal sounds for 2

minutes. **→|** and time setting flash in the display.

The oven turns off.

5. Press any button or open the oven door to stop the signal.
6. Turn the knob for the heating functions to the off position.

SETTING THE MINUTE MINDER

Minute minder can be both set when the oven is turned on and off.

1. Press **⏸** again and again until **🔔** starts to flash.
2. Press **+** or **-** to set the seconds and then the minutes.
When the time you set is longer than 60 minutes, **hr** flash in the display.
3. Set the hours.
4. The MINUTE MINDER starts automatically after 5 seconds.
After 90% of the set time the signal sounds.
5. When the set time ends the signal sounds for 2 minutes. "00:00" and **🔔** flash in the display. Press any button to stop the signal.

COUNT UP TIMER

To reset the Count Up Timer, press and hold **+** and **-**. The timer starts to count up again.

INSERTING THE ACCESSORIES

Wire shelf:

Push the shelf between the guide bars of the shelf support and make sure that the feet point down.

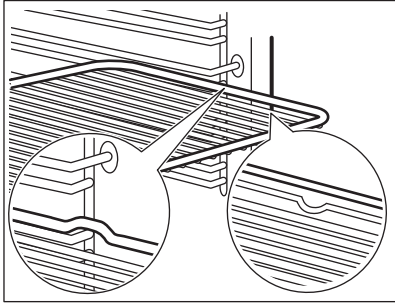

Deep pan:
Push the deep pan between the guide bars of the shelf support.

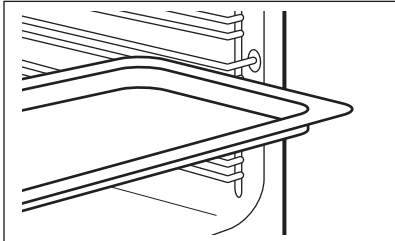

Wire shelf and deep pan together:
Push the deep pan between the guide bars of the shelf support and the wire shelf on the guide bars above.

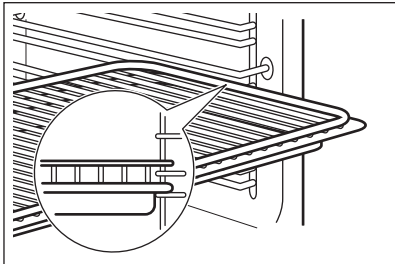

i Small indentation at the top increase safety. The indentations are also anti-tip devices. The high rim around the shelf prevents cookware from slipping of the shelf.

TRIVET AND GRILL- / ROASTING PAN



WARNING! Be careful when you remove the accessories from a hot oven. There is a risk of burns.

You can use the trivet to roast larger pieces of meat or poultry on one shelf position.

1. Put the trivet into the deep pan so that the supports of the wire shelf point up.

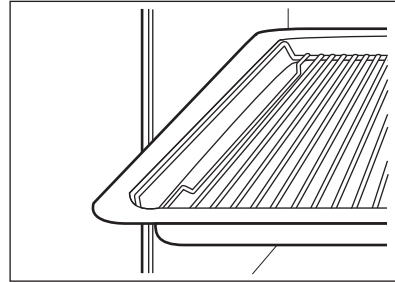

2. Put the deep pan into the oven on the necessary shelf position.

You can use the trivet to grill flat dishes in large quantities and to toast.

1. Put the trivet into the deep pan so that the supports of the wire shelf point down.

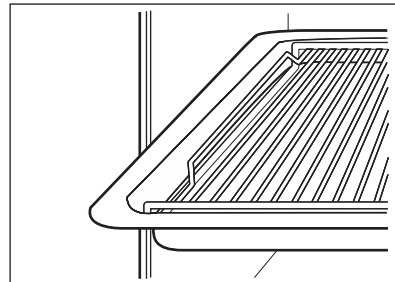



2. Put the deep pan into the oven on the necessary shelf position.

ADDITIONAL FUNCTIONS

USING THE CHILD LOCK

When the Child Lock is on the oven cannot be turned on accidentally.

1. Ensure the knob for the oven functions is in the off position.
2. Press and hold  and  at the same time for 2 seconds.

The signal sounds. SAFE and  appear on the display. The door is locked.

 The symbol  appear on the display also when Pyrolysis function operates.

To turn off the Child Lock, repeat step 2.

RESIDUAL HEAT INDICATOR

When you turn off the oven, the display shows the residual heat indicator  if the temperature in the oven is more than 40 °C.

AUTOMATIC SWITCH-OFF

For safety reasons the oven turns off automatically after some time if a heating function operates and you do not change the oven temperature.

Temperature (°C)	Switch-off time (h)
30 - 115	12.5

Temperature (°C)	Switch-off time (h)
120 - 195	8.5
200 - 245	5.5
250 - maximum	1.5

After an automatic switch-off, press any button to operate the oven again.

 The Automatic switch-off does not work with the functions: Light, Duration, End.

COOLING FAN

When the oven operates, the cooling fan turns on automatically to keep the surfaces of the oven cool. If you turn off the oven, the cooling fan can continue to operate until the oven cools down.

SAFETY THERMOSTAT

Incorrect operation of the oven or defective components can cause dangerous overheating. To prevent this, the oven has a safety thermostat which interrupts the power supply. The oven turns on again automatically when the temperature drops.

HINTS AND TIPS

 **WARNING!** Refer to Safety chapters.

 The temperature and baking times in the tables are guidelines only. They depend on the recipes and the quality and quantity of the ingredients used.

COOKING RECOMMENDATIONS

The oven has five shelf positions.

Count the shelf positions from the bottom of the oven floor.

Your oven may bake or roast differently to the oven you had before. The below tables provide you with the standard settings for temperature, cooking time and shelf position.

If you cannot find the settings for a special recipe, look for the similar one.

The oven has a special system which circulates the air and constantly recycles the steam. With this system you can cook in a steamy environment and keep the food soft inside and crusty outside. It decreases the cooking time and energy consumption.

Baking cakes

Do not open the oven door before 3/4 of the set cooking time is up.

If you use two baking trays at the same time, keep one empty level between them.

Cooking meat and fish

Use a deep pan for very fatty food to prevent the oven from stains that can be permanent.

Leave the meat for approximately 15 minutes before carving so that the juice does not seep out.

To prevent too much smoke in the oven during roasting, add some water into the deep pan. To prevent the smoke condensation, add water each time after it dries up.

Initially, monitor the performance when you cook. Find the best settings (heat setting, cooking time, etc.) for your cookware, recipes and quantities when you use this appliance.

Cooking times

Cooking times depend on the type of food, its consistency, and volume.

BAKING AND ROASTING

Cakes

Food	Top / Bottom Heat		True Fan Cooking		Time (min)	Comments
	Temperature (°C)	Shelf position	Temperature (°C)	Shelf position		
Whisked recipes	170	2	160	3 (2 and 4)	45 - 60	In a cake mould
Short-bread dough	170	2	160	3 (2 and 4)	20 - 30	In a cake mould
Buttermilk cheese-cake	170	1	165	2	80 - 100	In a 26 cm cake mould
Apple cake (Apple pie) ¹⁾	170	2	160	2 (left and right)	80 - 100	In two 20 cm cake moulds on a wire shelf
Strudel	175	3	150	2	60 - 80	In a baking tray
Jam-tart	170	2	165	2 (left and right)	30 - 40	In a 26 cm cake mould
Sponge cake	170	2	150	2	40 - 50	In a 26 cm cake mould
Christmas cake / Rich fruit cake ¹⁾	160	2	150	2	90 - 120	In a 20 cm cake mould
Plum cake ¹⁾	175	1	160	2	50 - 60	In a bread tin
Small cakes - one level ¹⁾	170	3	150 - 160	3	20 - 30	In a baking tray

Food	Top / Bottom Heat		True Fan Cooking		Time (min)	Comments
	Temperature (°C)	Shelf position	Temperature (°C)	Shelf position		
Small cakes - two levels ¹⁾	-	-	140 - 150	2 and 4	25 - 35	In a baking tray
Small cakes - three levels ¹⁾	-	-	140 - 150	1, 3 and 5	30 - 45	In a baking tray
Biscuits / pastry stripes - one level	140	3	140 - 150	3	25 - 45	In a baking tray
Biscuits / pastry stripes - two levels	-	-	140 - 150	2 and 4	35 - 40	In a baking tray
Biscuits / pastry stripes - three levels	-	-	140 - 150	1, 3 and 5	35 - 45	In a baking tray
Meringues - one level	120	3	120	3	80 - 100	In a baking tray
Meringues - two levels ¹⁾	-	-	120	2 and 4	80 - 100	In a baking tray
Buns ¹⁾	190	3	190	3	12 - 20	In a baking tray
Eclairs - one level	190	3	170	3	25 - 35	In a baking tray
Eclairs - two levels	-	-	170	2 and 4	35 - 45	In a baking tray
Plate tarts	180	2	170	2	45 - 70	In a 20 cm cake mould
Rich fruit cake	160	1	150	2	110 - 120	In a 24 cm cake mould

Food	Top / Bottom Heat		True Fan Cooking		Time (min)	Comments
	Temperature (°C)	Shelf position	Temperature (°C)	Shelf position		
Victoria sandwich ¹⁾	170	1	160	2 (left and right)	30 - 50	In a 20 cm cake mould

1) Preheat the oven for 10 minutes.

Bread and pizza

Food	Top / Bottom Heat		True Fan Cooking		Time (min)	Comments
	Temperature (°C)	Shelf position	Temperature (°C)	Shelf position		
White bread ¹⁾	190	1	190	1	60 - 70	1 - 2 pieces, 500 gr per piece
Rye bread	190	1	180	1	30 - 45	In a bread tin
Bread rolls ¹⁾	190	2	180	2 (2 and 4)	25 - 40	6 - 8 rolls in a baking tray
Pizza ¹⁾	230 - 250	1	230 - 250	1	10 - 20	In a baking tray or a deep pan
Scones ¹⁾	200	3	190	3	10 - 20	In a baking tray

1) Preheat the oven for 10 minutes.

Flans

Food	Top / Bottom Heat		True Fan Cooking		Time (min)	Comments
	Temperature (°C)	Shelf position	Temperature (°C)	Shelf position		
Pasta flan	200	2	180	2	40 - 50	In a mould

Food	Top / Bottom Heat		True Fan Cooking		Time (min)	Comments
	Temperature (°C)	Shelf position	Temperature (°C)	Shelf position		
Vegetable flan	200	2	175	2	45 - 60	In a mould
Quiches ¹⁾	180	1	180	1	50 - 60	In a mould
Lasagne ¹⁾	180 - 190	2	180 - 190	2	25 - 40	In a mould
Cannelloni ¹⁾	180 - 190	2	180 - 190	2	25 - 40	In a mould

1) Preheat the oven for 10 minutes.

Meat

Food	Top / Bottom Heat		True Fan Cooking		Time (min)	Comments
	Temperature (°C)	Shelf position	Temperature (°C)	Shelf position		
Beef	200	2	190	2	50 - 70	On a wire shelf
Pork	180	2	180	2	90 - 120	On a wire shelf
Veal	190	2	175	2	90 - 120	On a wire shelf
English roast beef, rare	210	2	200	2	50 - 60	On a wire shelf
English roast beef, medium	210	2	200	2	60 - 70	On a wire shelf
English roast beef, well done	210	2	200	2	70 - 75	On a wire shelf
Shoulder of pork	180	2	170	2	120 - 150	With rind
Shin of pork	180	2	160	2	100 - 120	2 pieces
Lamb	190	2	175	2	110 - 130	Leg

Food	Top / Bottom Heat		True Fan Cooking		Time (min)	Comments
	Temperature (°C)	Shelf position	Temperature (°C)	Shelf position		
Chicken	220	2	200	2	70 - 85	Whole
Turkey	180	2	160	2	210 - 240	Whole
Duck	175	2	220	2	120 - 150	Whole
Goose	175	2	160	1	150 - 200	Whole
Rabbit	190	2	175	2	60 - 80	Cut in pieces
Hare	190	2	175	2	150 - 200	Cut in pieces
Pheasant	190	2	175	2	90 - 120	Whole

Fish

Food	Top / Bottom Heat		True Fan Cooking		Time (min)	Comments
	Temperature (°C)	Shelf position	Temperature (°C)	Shelf position		
Trout / Sea bream	190	2	175	2	40 - 55	3 - 4 fish
Tuna fish / Salmon	190	2	175	2	35 - 60	4 - 6 fillets

GRILLING

Set the maximum temperature.

Preheat the oven for 3 minutes.

Use the fourth shelf position.

Food	Quantity		Time (min)	
	Pieces	Quantity (kg)	1st side	2nd side
Fillet steaks	4	0.8	12 - 15	12 - 14
Beef steaks	4	0.6	10 - 12	6 - 8
Sausages	8	-	12 - 15	10 - 12

Food	Quantity		Time (min)	
	Pieces	Quantity (kg)	1st side	2nd side
Pork chops	4	0.6	12 - 16	12 - 14
Chicken (cut in 2)	2	1	30 - 35	25 - 30
Kebabs	4	-	10 - 15	10 - 12
Breast of chicken	4	0.4	12 - 15	12 - 14
Hamburger	6	0.6	20 - 30	-
Fish fillet	4	0.4	12 - 14	10 - 12
Toasted sandwiches	4 - 6	-	5 - 7	-
Toast	4 - 6	-	2 - 4	2 - 3

TURBO GRILLING

Use the first or the second shelf position.

Beef

Preheat the oven.

To calculate the roasting time multiple the time given in the table below by the centimetres of thickness of the fillet.

Food	Temperature (°C)	Time (min)
Roast beef or fillet, rare	190 - 200	5 - 6
Roast beef or fillet, medium	180 - 190	6 - 8
Roast beef or fillet, well done	170 - 180	8 - 10

Pork

Food	Temperature (°C)	Time (min)
Shoulder, neck, ham joint, 1 - 1.5 kg	160 - 180	90 - 120

Food	Temperature (°C)	Time (min)
Chop, spare rib, 1 - 1.5 kg	170 - 180	60 - 90
Meat loaf, 0.75 - 1 kg	160 - 170	50 - 60
Pork knuckle (pre-cooked), 0.75 - 1 kg	150 - 170	90 - 120

Veal

Food	Temperature (°C)	Time (min)
Roast veal, 1 kg	160 - 180	90 - 120
Knuckle of veal, 1.5 - 2 kg	160 - 180	120 - 150

Lamb

Food	Temperature (°C)	Time (min)
Leg of lamb, roast lamb, 1 - 1.5 kg	150 - 170	100 - 120
Saddle of lamb, 1 - 1.5 kg	160 - 180	40 - 60

Poultry

Food	Temperature (°C)	Time (min)
Poultry portions, 0.2 - 0.25 kg each	200 - 220	30 - 50
Chicken, half, 0.4 - 0.5 kg each	190 - 210	35 - 50
Chicken, poulard, 1 - 1.5 kg	190 - 210	50 - 70

Food	Temperature (°C)	Time (min)
Duck, 1.5 - 2 kg	180 - 200	80 - 100
Goose, 3.5 - 5 kg	160 - 180	120 - 180
Turkey, 2.5 - 3.5 kg	160 - 180	120 - 150
Turkey, 4 - 6 kg	140 - 160	150 - 240

Fish (steamed)

Food	Temperature (°C)	Time (min)
Whole fish, 1 - 1.5 kg	210 - 220	40 - 60

MOIST FAN BAKING

For the best results follow suggestions listed in the table below.

Food	Accessories	Temperature (°C)	Shelf position	Time (min)
Sweet rolls, 12 pieces	baking tray or dripping pan	180	2	20 - 30
Rolls, 9 pieces	baking tray or dripping pan	180	2	30 - 40
Pizza, frozen, 0.35 kg	wire shelf	220	2	10 - 15
Swiss roll	baking tray or dripping pan	170	2	25 - 35
Brownie	baking tray or dripping pan	175	3	25 - 30
Soufflé, 6 pieces	ceramic ramekins on wire shelf	200	3	25 - 30
Sponge flan base	flan base tin on wire shelf	180	2	15 - 25
Victoria Sandwich	baking dish on wire shelf	170	2	40 - 50

Food	Accessories	Temperature (°C)	Shelf position	Time (min)
Poached fish, 0.3 kg	baking tray or dripping pan	180	3	20 - 25
Whole fish, 0.2 kg	baking tray or dripping pan	180	3	25 - 35
Fish fillet, 0.3 kg	pizza pan on wire shelf	180	3	25 - 30
Poached meat, 0.25 kg	baking tray or dripping pan	200	3	35 - 45
Shashlik, 0.5 kg	baking tray or dripping pan	200	3	25 - 30
Cookies, 16 pieces	baking tray or dripping pan	180	2	20 - 30
Macarons, 20 pieces	baking tray or dripping pan	180	2	25 - 35
Muffins, 12 pieces	baking tray or dripping pan	170	2	30 - 40
Savory pastry, 16 pieces	baking tray or dripping pan	180	2	25 - 30
Short crust biscuits, 20 pieces	baking tray or dripping pan	150	2	25 - 35
Tartlets, 8 pieces	baking tray or dripping pan	170	2	20 - 30
Poached vegetables, 0.4 kg	baking tray or dripping pan	180	3	35 - 45
Vegetarian omelette	pizza pan on wire shelf	200	3	25 - 30
Vegetables, mediterranean 0.7 kg	baking tray or dripping pan	180	4	25 - 30

DEFROST

Food	Quantity (kg)	Defrosting time (min)	Further defrosting time (min)	Comments
Chicken	1.0	100 - 140	20 - 30	Place the chicken on an upturned saucer placed on a large plate. Turn halfway through.
Meat	1.0	100 - 140	20 - 30	Turn halfway through.
Meat	0.5	90 - 120	20 - 30	Turn halfway through.

Food	Quantity (kg)	Defrosting time (min)	Further defrosting time (min)	Comments
Trout	0.15	25 - 35	10 - 15	-
Strawberries	0.3	30 - 40	10 - 20	-
Butter	0.25	30 - 40	10 - 15	-
Cream	2 x 0.2	80 - 100	10 - 15	Cream can also be whipped when still slightly frozen in places.
Gateau	1.4	60	60	-

DRYING - TRUE FAN COOKING

Cover trays with grease proof paper or baking parchment.

For a better result, stop the oven halfway through the drying time, open the door and let it cool down for one night to complete the drying.

Vegetables

For one tray use the third shelf position.

For 2 trays use the first and fourth shelf position.

Food	Temperature (°C)	Time (h)
Beans	60 - 70	6 - 8
Peppers	60 - 70	5 - 6
Vegetables for sour	60 - 70	5 - 6
Mushrooms	50 - 60	6 - 8
Herbs	40 - 50	2 - 3

Fruit

Food	Temperature (°C)	Time (h)	Shelf position	
			1 position	2 positions
Plums	60 - 70	8 - 10	3	1 / 4
Apricots	60 - 70	8 - 10	3	1 / 4
Apple slices	60 - 70	6 - 8	3	1 / 4
Pears	60 - 70	6 - 9	3	1 / 4

INFORMATION FOR TEST INSTITUTES

Tests according to IEC 60350-1.

Food	Function	Accessories	Shelf position	Temperature (°C)	Time (min)	Comments
Small cake	Conventional Cooking	Baking tray	3	170	20 - 30	Put 20 small cakes per one baking tray.
Small cake	True Fan Cooking / Fan Cooking	Baking tray	3	150 - 160	20 - 35	Put 20 small cakes per one baking tray.
Small cake	True Fan Cooking / Fan Cooking	Baking tray	2 and 4	150 - 160	20 - 35	Put 20 small cakes per one baking tray.
Apple pie	Conventional Cooking	Wire shelf	2	180	70 - 90	Use 2 tins (20 cm diameter), diagonally shifted.
Apple pie	True Fan Cooking / Fan Cooking	Wire shelf	2	160	70 - 90	Use 2 tins (20 cm diameter), diagonally shifted.
Fatless-ponge cake	Conventional Cooking	Wire shelf	2	170	40 - 50	Use a cake mould (26 cm diameter). Preheat the oven for 10 minutes.
Fatless-ponge cake	True Fan Cooking / Fan Cooking	Wire shelf	2	160	40 - 50	Use a cake mould (26 cm diameter). Preheat the oven for 10 minutes.
Fatless-ponge cake	True Fan Cooking / Fan Cooking	Wire shelf	2 and 4	160	40 - 60	Use a cake mould (26 cm diameter). Diagonally shifted. Preheat the oven for 10 minutes.
Short bread	True Fan Cooking / Fan Cooking	Baking tray	3	140 - 150	20 - 40	-
Short bread	True Fan Cooking / Fan Cooking	Baking tray	2 and 4	140 - 150	25 - 45	-
Short bread	Conventional Cooking	Baking tray	3	140 - 150	25 - 45	-

Food	Function	Accessories	Shelf position	Temperature (°C)	Time (min)	Comments
Toast 4 - 6 pieces	Grilling	Wire shelf	4	max.	2 - 3 minutes first side; 2 - 3 minutes second side	Preheat the oven for 3 minutes.
Beef burger 6 pieces, 0.6 kg	Grilling	Wire shelf and dripping pan	4	max.	20 - 30	Put the wire shelf on the fourth level and the dripping pan on the third level of the oven. Turn the food half-way through the cooking time. Preheat the oven for 3 minutes.

CARE AND CLEANING



WARNING! Refer to Safety chapters.

NOTES ON CLEANING

Clean the front of the oven with a soft cloth with warm water and a mild cleaning agent.

To clean metal surfaces, use a dedicated cleaning agent.

Clean the oven interior after each use. Fat accumulation or other food remains may result in a fire. The risk is higher for the grill pan.

Clean all accessories after each use and let them dry. Use a soft cloth with warm water and a cleaning agent. Do not clean the accessories in the dishwasher.

Clean stubborn dirt with a special oven cleaner.

If you have nonstick accessories, do not clean them using aggressive agents, sharp-edged objects or a dishwasher. It can cause damage to the nonstick coating.

Moisture can condense in the oven or on the door glass panels. To decrease the condensation, operate the oven for 10 minutes before cooking. Clean the moisture from the cavity after each use.

STAINLESS STEEL OR ALUMINIUM OVENS

Clean the oven door with a damp cloth or sponge only. Dry it with a soft cloth.

Do not use steel wool, acids or abrasive materials as they can damage the oven surface. Clean the oven control panel with the same precautions.

REMOVING THE SHELF SUPPORTS

To clean the oven, remove the shelf supports.



CAUTION! Be careful when you remove the shelf supports.

1. Pull the front of the shelf support away from the side wall.

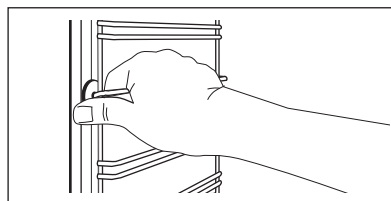

2. Pull the rear end of the shelf support away from the side wall and remove it.

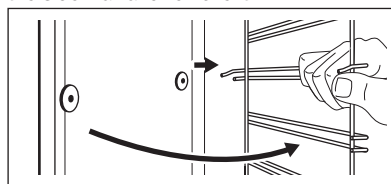

Install the removed accessories in the opposite sequence.

PYROLYSIS



CAUTION! Remove all accessories and removable shelf supports.



Do not start the Pyrolysis if you did not fully close the oven door. In some models, the display shows "C3" when this error occurs.



WARNING! The oven becomes very hot. There is a risk of burns.



CAUTION! If there are other appliances installed in the same cabinet, do not use them when the Pyrolysis function operates. It can cause damage to the appliance.

1. Wipe out the cavity with a wet, soft cloth.
2. Clean the inner side of the door with hot water, so that the residues do not burn from the hot air.
3. Set the Pyrolysis function. Refer to "Daily use" chapter, "Oven Functions".
4. When |→| flashes, press + or - to set the pyrolysis duration:

Option	Description
P1	Light cleaning. Duration: 1 h.
P2	Normal cleaning. Duration: 1 h 30 min.

Press ⏸ or turn the knob for the temperature to start the pyrolysis. You can use the END function to delay the start of the cleaning.

During the pyrolysis the oven lamp is off.

5. When the oven is at the set temperature, the door locks. The display shows 🔒 and the bars of the heat indicator until the door unlocks. To stop pyrolysis before it is completed, turn the knob for the oven functions to the off position.
6. When pyrolysis is completed, the display shows the time of day. The oven door stays locked.

7. When the oven is cool again, the door unlocks.

CLEANING REMINDER

To remind you that the pyrolysis is necessary, PYR flashes in the display for 10 seconds after each activation and deactivation of the oven.



The cleaning reminder goes out:

- after the end of the pyrolysis.
- if you press + and - at the same time while PYR flashes in the display.

REMOVING AND INSTALLING DOOR

The oven door has three glass panels. You can remove the oven door and the internal glass panels to clean them. Read the whole "Removing and installing door" instruction before you remove the glass panels.



The oven door may close if you try to remove the glass panels before you remove the oven door.



CAUTION! Do not use the oven without the glass panels.

1. Open the door fully and hold both hinges.

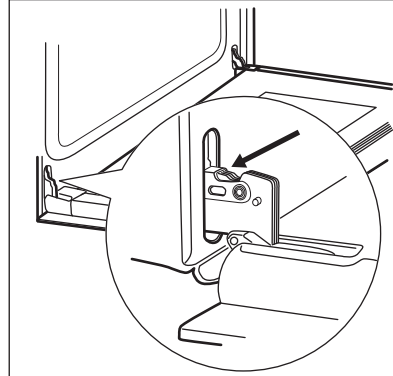

2. Lift and turn the levers fully on both hinges.

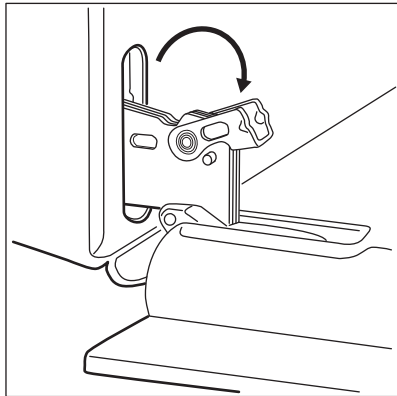

3. Close the oven door halfway to the first opening position. Then lift and pull forward and remove the door from its seat.

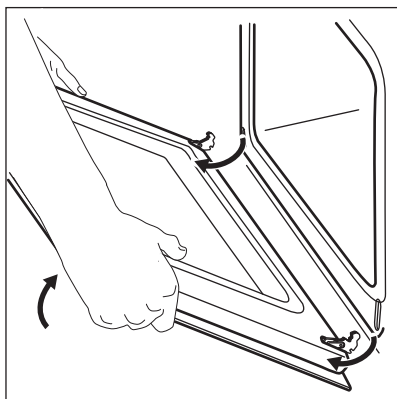

4. Put the door on a soft cloth on a stable surface.
5. Hold the door trim (B) on the top edge of the door at the two sides and push inwards to release the clip seal.

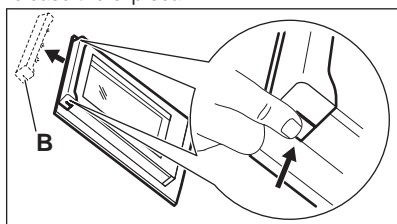

6. Pull the door trim to the front to remove it.
7. Hold the door glass panels by their top edge and carefully pull them out one by one. Start from the top panel. Make sure the glass slides out of the supports completely.

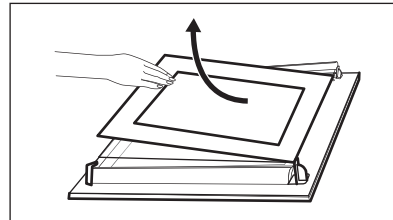

8. Clean the glass panels with water and soap. Dry the glass panels carefully. Do not clean the glass panels in the dishwasher.

When the cleaning is completed, install the glass panels and the oven door.

Make sure that you put the glass panels (A and B) back in the correct sequence. Check for the symbol / printing on the side of the glass panel, each of the glass panels looks different to make the disassembly and assembly easier.

When installed correctly the door trim clicks.

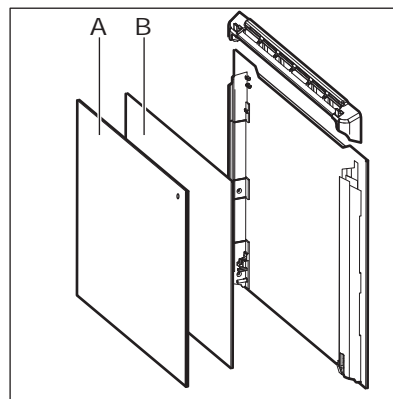

Make sure that you install the middle panel of glass in the seats correctly.

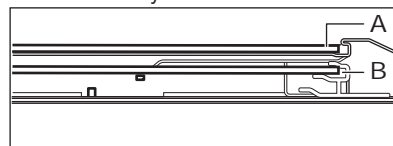

REPLACING THE LAMP



WARNING! Risk of electric shock. The lamp can be hot.

1. Turn off the oven. Wait until the oven is cooled down.
2. Disconnect the oven from the mains.
3. Put a cloth on the bottom of the cavity.



CAUTION! Always hold the halogen lamp with a cloth to prevent grease residue from burning on the lamp.

2. Clean the glass cover.
3. Replace the lamp with a suitable 300 °C heat-resistant lamp.
4. Install the glass cover.

The back lamp

1. Turn the lamp glass cover to remove it.





TROUBLESHOOTING



WARNING! Refer to Safety chapters.

WHAT TO DO IF...

Problem	Possible cause	Remedy
You cannot activate or operate the oven.	The oven is not connected to an electrical supply or it is connected incorrectly.	Check if the oven is correctly connected to the electrical supply (refer to the connection diagram if available).
The oven does not heat up.	The oven is deactivated.	Activate the oven.
The oven does not heat up.	The clock is not set.	Set the clock.
The oven does not heat up.	The necessary settings are not set.	Make sure that the settings are correct.
The oven does not heat up.	The automatic switch-off is activated.	Refer to "Automatic switch-off".
The oven does not heat up.	The Child Lock is on.	Refer to "Using the Child Lock".
The oven does not heat up.	The fuse is blown.	Make sure that the fuse is the cause of the malfunction. If the fuse is blown again and again, contact a qualified electrician.
The lamp does not operate.	The lamp is defective.	Replace the lamp.
It takes too long to cook the dishes or they cook too quickly.	The temperature is too low or too high.	Adjust the temperature if necessary. Follow the advice in the user manual.
Steam and condensation settle on the food and in the cavity of the oven.	You left the dish in the oven for too long.	Do not leave the dishes in the oven for longer than 15 - 20 minutes after the cooking process ends.
The display shows "C3".	The cleaning function does not operate. You did not fully close the door, or the door lock is defective.	Fully close the door.

Problem	Possible cause	Remedy
The display shows "F102".	<ul style="list-style-type: none"> ▪ You did not fully close the door. ▪ The door lock is defective. 	<ul style="list-style-type: none"> ▪ Fully close the door. ▪ Deactivate the oven with the house fuse or the safety switch in the fuse box and activate it again. ▪ If the display shows "F102" again, contact the Customer Care Department.
The display shows an error code that is not in this table.	There is an electrical fault.	<ul style="list-style-type: none"> ▪ Deactivate the oven with the house fuse or the safety switch in the fuse box and activate it again. ▪ If the display shows the error code again, contact the Customer Care Department.
The appliance is activated and does not heat up. The fan does not operate. The display shows "Demo".	The demo mode is activated.	<ol style="list-style-type: none"> 1. Deactivate the oven. 2. Press and hold the button . 3. The first digit on the display and Demo indicator start to blink. 4. Enter the code 2468 by pressing the buttons  or  to change the values and press  to confirm. 5. The next digit starts to blink. 6. Demo mode deactivates when you confirm the last digit and the code is correct.
The display shows "12.00".	There was a power cut.	Reset the clock.

SERVICE DATA

If you cannot find a solution to the problem yourself, contact your dealer or an Authorised Service Centre.

The necessary data for the service centre is on the rating plate. The rating plate is on the front frame of

the oven cavity. Do not remove the rating plate from the oven cavity.

We recommend that you write the data here:

Model (MOD.)
Product number (PNC)

We recommend that you write the data here:

Serial number (S.N.)

.....

INSTALLATION



WARNING! Refer to Safety chapters.

BUILDING IN

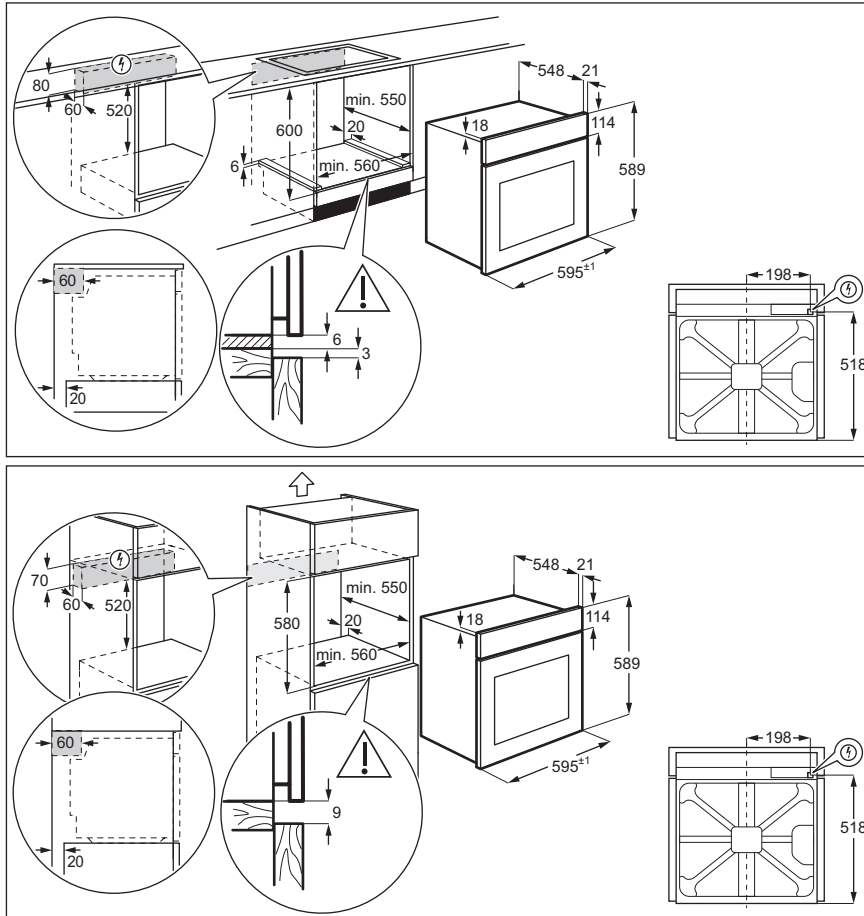

SECURING THE APPLIANCE TO THE CABINET

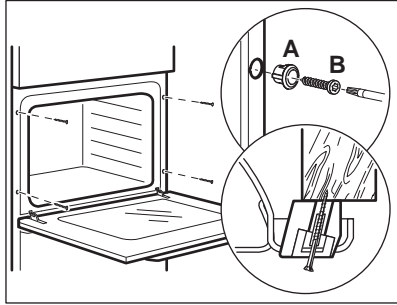

ELECTRICAL INSTALLATION

i The manufacturer is not responsible if you do not follow the safety precautions from the Safety chapters.

This appliance is supplied without a main plug and a main cable.

Applicable types of cables for Europe:

- Minimum size Cable / flex: 1,5 mm²
- Cable / flex type: H07 RN-F, H05 RN-F, H05 RRF, H05 VV-F, H05 V2V2-F (T90), H05 BB-F

Applicable types of cables for UK only

Connection via	Min. size cable / flex	Cable / flex type	Fuse
Oven Control Circuit	2,5 mm ²	PVC / PVC twin and earth	15 A min. 20 A max.



ENERGY EFFICIENCY

PRODUCT INFORMATION ACCORDING TO EU 65-66/2014

Supplier's name	Zanussi
Model identification	ZOP37902XU 949498090 ZOP37972BK 949498055 ZOP37982XK 949498054
Energy Efficiency Index	81.2
Energy efficiency class	A+
Energy consumption with a standard load, conventional mode	0.93 kWh/cycle
Energy consumption with a standard load, fan-forced mode	0.69 kWh/cycle
Number of cavities	1
Heat source	Electricity
Volume	72 l
Type of oven	Built-In Oven

Mass	ZOP37902XU	30.3 kg
	ZOP37972BK	31.6 kg
	ZOP37982XK	32.3 kg

EN 60350-1 - Household electric cooking appliances - Part 1: Ranges, ovens, steam ovens and grills - Methods for measuring performance.

ENERGY SAVING



The oven contains features which help you save energy during everyday cooking.

General hints

Make sure that the oven door is closed properly when the oven operates. Do not open the door too often during cooking. Keep the door gasket clean and make sure it is well fixed in its position.

Use metal dishes to improve energy saving.

When possible, do not preheat the oven before you put the food inside.

When the cooking duration is longer than 30 minutes, reduce the oven temperature to minimum 3 - 10 minutes before the end of the cooking time, depending on the duration of the cooking. The residual heat inside the oven will continue to cook.

ENVIRONMENTAL CONCERNS

Recycle materials with the symbol . Put the packaging in relevant containers to recycle it. Help protect the environment and human health by recycling waste of electrical and electronic appliances. Do not dispose of appliances marked

Use the residual heat to warm up other dishes.

Keep breaks between baking as short as possible when you prepare few dishes at one time.

Cooking with fan

When possible, use the cooking functions with fan to save energy.

Residual heat

If a programme with the Duration or End Time selection is activated and the cooking time is longer than 30 minutes, the heating elements automatically deactivate earlier in some oven functions.

The fan and lamp continue to operate.

Keep food warm

Choose the lowest possible temperature setting to use residual heat and keep a meal warm. The residual heat indicator or temperature appears on the display.

Moist Fan Baking

Function designed to save energy during cooking. When you use this function the lamp automatically turns off after 30 seconds.

with the symbol  with the household waste. Return the product to your local recycling facility or contact your municipal office.

WWW.ZANUSSI.COM/SHOP



CE

867348205-B-032019